

(IT) **Attenzione:** Istruzioni di montaggio per barre in alluminio.  
 (GB) **Attention:** Mounting instructions for aluminium bar carriers.  
 (E) **Atencion:** Instrucciones de montaje para barras portatodo en aluminio.  
 (D) **Achtung:** Montageanweisungen für Aluminium-Lastenträger.  
 (F) **Attention:** Notices de montage pour barres de portage en aluminium.  
 (NL) **Attentie:** Handleiding voor dakdragers gemaakt van aluminium.  
 (P) **Atenção:** Instruções de montagem para barras de tejadilho em alumínio.  
 (H) Szerelési utasítás alumínium tartórudakhoz.  
 (PL) **Uwaga:** Instrukcja montażu bagażników wykonanych ze aluminium.  
 (SLO) **Pozor:** Navodila za montažo nosilcev prtljažnika - aluminijastih.  
 (HR) Uputstvo za montažu aluminijaskih nosača.

**1** **ZOOM** **A** **B** **C** **D**

(IT) SVITARE  
(GB) UNSCREW  
(E) AFLOJAR  
(D) ABSCHRAUBEN  
(F) DEVISSER  
(NL) OPENSCHROEVEN  
(P) DESAPARAFUSAR  
(H) KICSAVARNI  
(PL) WYKRECIC  
(SLO) ODVITI  
(HR) ODVITI

(IT) INSERIRE  
(GB) INSERT  
(E) CUBRIR  
(D) STOPFEN  
(F) ENFILER  
(NL) BEVESTIG

(P) INSERIR  
(H) TOLJA FEL  
(PL) NALOZIC  
(SLO) VSTAVITI  
(HR) PREKRITI

(IT) AVVITARE  
(GB) TO SCREW  
(E) APRETAR  
(D) FESTSCHRAUBEN  
(F) VISSER  
(NL) VASTSCHROEVEN

(P) APERTAR  
(H) MEGHÚZNI  
(PL) WKRECIC  
(SLO) PRIVITI  
(HR) PRIČVRSTITI

**2** **ZOOM**

(IT) INSERIRE  
(GB) INSERT  
(E) CUBRIR  
(D) STOPFEN  
(F) ENFILER  
(NL) BEVESTIG

(P) INSERIR  
(H) TOLJA FEL  
(PL) NALOZIC  
(SLO) VSTAVITI  
(HR) PREKRITI

**3** **ZOOM**

(IT) MISURE PRECISE  
(GB) EXACT DIMENSIONS  
(E) MEDIDAS CORRECTAS  
(D) GENAUE MASSE  
(F) MESURES EXACTES  
(NL) EXACTE AFMETINGEN

(P) MEDIDAS PRECISAS  
(H) PONTOS MÉRET  
(PL) DOKŁADNE WYMIARY  
(SLO) TOČNE MERE  
(HR) PRECIZNE MJERE

(IT) MODELLI AUTO (GB) CARS (E) COCHES (D) WAGEN (F) VOITURES	(NL) AUTO (P) MODELO AUTO (H) AUTÓ TIPUS (PL) MODELE SAMOCHODÓW (SLO) MODELI AVTOMOBILOV (HR) MODELI AUTA	(IT) ANTERIORE (GB) FRONT (E) DELANTERO (D) VORDERE (F) AVANT	(NL) VOORSTEG. (P) À FRENTE (H) ELSŐ RÚD (PL) PRZODAJ (SLO) SPREDAJ (HR) PREDNJI	(IT) POST. (GB) REAR (E) TRASERO (D) HINTERE (F) ARRIERE	(NL) ACHTERSTE G. (P) ATRÁS (H) HÁTSÓ RÚD (PL) TYŁ (SLO) ZADAJ (HR) STRAŽNJI
AUDI 100 (91->)		67 mm		82 mm	
AUDI 80 (86->)		100 mm		111 mm	
AUDI A3 (->02)		67 mm		87 mm	
AUDI A3 5P (->02)		71 mm		87 mm	
AUDI A3 5P SPORTBACK NO RAILS (03->12)		32 mm		52 mm	
AUDI A6 (->96)		35 mm		47 mm	
AUDI A6 (97->04)		35 mm		30 mm	
AUDI A6 (04->10)		108 mm		106 mm	
BMW SERIE 5 (03->10)		98 mm		98 mm	
BMW SERIE 5 TOURING NO RAILS (04->10)		99 mm		109 mm	
DAEWOO EVANDA		81 mm		91 mm	
DAEWOO KALOS 5P		47 mm		61 mm	
DAEWOO LANOS 4-5P		86 mm		90 mm	
DAEWOO NUBIRA I 4-5P (->02)		70 mm		75 mm	
DAIHATSU SIRION 5P (->05)		46 mm		57 mm	
DAIHATSU TERIOS NO RAILS (06->)		105 mm		115 mm	
FORD FIESTA 5P (08->)		36 mm		47 mm	
HONDA ACCORD 5P (95->02)		70 mm		62 mm	



HONDA CIVIC 5P (01->06)	45 mm	48 mm
HONDA STREAM	125 mm	130 mm
HYUNDAI ACCENT 4-5 P (00->06)	65 mm	62 mm
KIA SHUMA	71 mm	71 mm
MERCEDES CLASSE A (->04) passo lungo long wheelbase / version lounge / langer Radstand	46 mm	63 mm
PEUGEOT 605	110 mm	110 mm
RENAULT ESPACE (->96) Senza predispos. Orig. Without original mounting points Sans points de fixation d'origine Ohne original Befestigungspunkten	75 mm	75 mm
RENAULT ESPACE (97->04) Senza predispos. Orig. Without original mounting points Sans points de fixation d'origine Ohne original Befestigungspunkten	69 mm	77 mm
ROVER 600	70 mm	65 mm
ROVER 75	32 mm	32 mm
SEAT ALTEA (05->09)	109 mm	119 mm
SEAT ALTEA (09->)	118 mm	129 mm
SEAT AROSA	54 mm	78 mm
SEAT TOLEDO (04->09)	109 mm	121 mm
SUZUKI ALTO 5P (02->09)	120 mm	136 mm
TOYOTA COROLLA 5P (02->07)	125 mm	110 mm
VOLVO S40 (96->04)	75 mm	81 mm
VOLVO S40 (04->12)	92 mm	87 mm
VOLVO V40 NO RAILS (96->04)	67 mm	87 mm
VOLVO V50 NO RAILS (04->12)	97 mm	103 mm
VW LUPO	48 mm	72 mm
VW PASSAT (88->96)	72 mm	97 mm
VW PASSAT (97->99)	45 mm	45 mm
VW PASSAT (00->05)	37 mm	34 mm
VW PASSAT SW NO RAILS (00->05)	37 mm	43 mm

**4**

(IT) AVVITARE (A FONDO)  
(GB) TO SCREW (DOWN)  
(E) APRETAR (A FONDO)  
(D) FESTSCHRAUBEN  
(F) VISSER (À FOND)  
(NL) VASTSCHROEVEN  
(P) APERTAR POR BAIXO  
(H) MEGHÚZNI  
(PL) WKRECIC DO KONCA  
(SLO) PRIVITI (DO KONCA)  
(HR) PRIČVRSTITI (DO KRAJA)

**10 Nm**

**5** **B**

(IT) INSERIRE  
(GB) INSERT  
(E) CUBRIR  
(D) STOPFEN  
(F) ENFILER  
(P) INSERIR  
(NL) BEVESTIG  
(H) TOLJA FEL  
(PL) NALOZIC  
(SLO) VSTAVITI  
(HR) PREKRITI

**6** **A** **B**

(IT) TAGLIARE  
(GB) TO CUT  
(E) CORTAR  
(D) SCHNEIDEN  
(F) COUPER  
(NL) SNIJDEN  
(P) CORTAR  
(H) ELVÁGNI  
(PL) OBCIAC  
(SLO) ODREZATI  
(HR) ODREZATI

(IT) INSERIRE  
(GB) INSERT  
(E) CUBRIR  
(D) STOPFEN  
(F) ENFILER  
(P) INSERIR  
(NL) BEVESTIG  
(H) TOLJA FEL  
(PL) NALOZIC  
(SLO) VSTAVITI  
(HR) PREKRITI

**7**

(IT) INSERIRE  
(GB) INSERT  
(E) CUBRIR  
(D) STOPFEN  
(F) ENFILER  
(P) INSERIR  
(NL) BEVESTIG  
(H) TOLJA FEL  
(PL) NALOZIC  
(SLO) VSTAVITI  
(HR) PREKRITI

(IT) INSERIRE (P) INSERIR  
(GB) INSERT (H) TOLJA FEL  
(E) CUBRIR (PL) NALOZIC  
(D) STOPFEN (SLO) VSTAVITI  
(F) ENFILER (HR) PREKRITI  
(NL) BEVESTIG

(IT) TAGLIARE (P) CORTAR  
(GB) TO CUT (H) ELVÁGNI  
(E) CORTAR (PL) OBCIAC  
(D) SCHNEIDEN (SLO) ODREZATI  
(F) COUPER (HR) ODREZATI  
(NL) SNIJDEN

**8**

(IT) MONTAGGIO GANASCINE  
(GB) HOW TO ASSEMBLE THE CLAMPS  
(E) COMO MONTAR LAS FIJACIONES  
(D) ZUSAMMENBAU DER SPANNBACKEN  
(F) MONTAGE PATTE  
(NL) MONTAGE VAN DE KLEMMEN  
(P) COMO FIXAR OS SUPORTES  
(H) RÖGZITŐ FÜLEK  
(PL) MONTAZ SZCZEK MOCUJACYCH  
(SLO) MONTAŽA NAPENJALNIKA  
(HR) MONTAŽA ČELJUSTI

**9**

(IT) PULIRE IL TETTO  
(GB) CLEAN THE ROOF  
(E) LIMPIAR EL TECHO  
(D) DACH REINIGEN  
(F) NETTOYER LE TOIT  
(NL) DAK SCHOONMAKEN  
(P) LIMPAR O TEJADILHO  
(H) TISZTÍTSA MEG A TETŐT  
(PL) WYCZYSZIC DACH  
(SLO) OČISTITI STREHO  
(HR) ČIŠĆENJE KROVA

**10**

OPTIMUM  
700 mm

**11**

OK  
NO

(IT) CENTRARE IL P. TUTTO SUL TETTO  
(GB) CENTRE THE UNIVERSAL BAR CARRIER ON THE ROOF  
(E) CENTRAR EL PORTAEQUIPAJES SOBRE EL TECHO  
(D) LASTENTRÄGER AUF DEM DACH ZENTRIEREN  
(F) CENTRER LE PORTE-TOUT SUR LE TOIT  
(NL) PLAATS DE UNIVERSELE DRAGER IN HET MIDDEN VAN HET DAK  
(P) CENTRAR AS BARRAS PORTA BAGAGENS NO TEJADILHO  
(H) HELYEZZE KÖZÉPRE A RUDAKAT  
(PL) WYSRODKOWAC BAGAZNIK NA DACHU  
(SLO) CENTRIRATI PRTLJAŽNIK NA STREHO  
(HR) CENTRIRATI NOSAČE NA KROV

(IT) MODELLI CON PREDISPOSIZIONE DELLA CASA AUTO  
(GB) CARS WITH PRE-EXISTING FIXING POINT FROM MANUFACTURER  
(E) MODELOS CON PREDISPOSICION DEL FABRICANTE  
(D) AUTOS MIT VOM HERSTELLER VORGESEHENE BEFESTIGUNGSPUNKTE  
(F) VOITURES AVEC POINTS DE RÉPÈRE PRÉVUS PAR LE CONSTRUCTEUR  
(NL) AUTO'S MET DOOR DE FABRIKANT VOORZIENE MONTAGEPUNTEN  
(P) VIATURAS COM PONTOS DE FIXAÇÃO DO CONSTRUTOR PRÉ-EXISTENTES  
(H) FELHÉLYEZÉS GYÁRTÓ ÁLTAL KIJELÖLT PONTRA  
(PL) SAMOCHODY Z PRZEWDZIANYMI PUNKTAMI UMOCOWANIA  
(SLO) MODELI Z PREDVIDENIM LEŽIŠČEM S STRANI PROIZVAJALCA  
(HR) TVORNIČKI PRIPREMLJENI MODELI

**12**

"À TROUVER SUR LE BATTANT DE LA PORTE OU DANS LE MANUAL TECHNIQUE DE LA VOITURE"

(IT) AVVITARE  
(GB) TO SCREW  
(E) APRETAR  
(D) FESTSCHRAUBEN  
(F) VISSER  
(NL) VASTSCHROEVEN  
(P) APERTAR  
(H) MEGHÚZNI  
(PL) WKRECIC  
(SLO) PRIVITI  
(HR) PRIČVRSTITI

5 Nm

(IT) MODELLI AUTO (GB) CARS (E) COCHES (D) WAGEN (F) VOITURES (NL) AUTO (P) MODELO AUTO (H) AUTÓ TIPUS (PL) MODELE SAMOCHODÓW (SLO) MODELI AVTOMOBILOV (HR) MODELI AUTA	(IT) ANTERIORE (GB) FRONT (E) DELANTERO (D) VORDERE (F) AVANT (NL) VOORSTE G. (P) À FRENTE (H) ELSŐ RÚD (PL) PRZOD (SLO) SPREDAJ (HR) PREDNJI	(IT) POSTERIORE (GB) REAR (E) TRASERO (D) HINTERE (F) ARRIERE (NL) ACHTERSTE G. (P) ATRÁS (H) HÁTSÓ RÚD (PL) TYL (SLO) ZADAJ (HR) STRAŽNJI
AUDI A3 5P (->02)	T	Z
AUDI 80 (86 ->)	T	Z
AUDI 100 (91->)	T	Z
AUDI A6 (->96)	T	Z
AUDI A6 (97->04)	T	Z
BMW SERIE 5 (03->10)	T	Z
BMW SERIE 5 TOURING NO RAILS (04->10)	T	Z
HONDA ACCORD 5P (95->02)	T	Z
HONDA CIVIC 5P (01->06)	T	Z
HYUNDAI ACCENT 4-5 P (00->06)	T	Z
ROVER 600	T	Z
SEAT AROSA	T	Z
VW LUPO	T	Z
VW PASSAT (88->96)	T	Z
VW PASSAT (97->99)	T	Z
VW PASSAT (00->05)	T	Z
VW PASSAT SW NO RAILS (00->05)	T	Z

(IT) MODELLI SENZA PREDISPOSIZIONE DELLA CASA AUTO  
(GB) CARS WITHOUT PRE-EXISTING FIXING POINT  
(E) PARA COCHES SIN PREDISPOSICION DEL FABRICANTE  
(D) AUTOS OHNE VOM HERSTELLER VORGESEHENE BEFESTIGUNGSPUNKTE  
(F) VOITURES SANS POINTS DE RÉPÈRE PRÉVUS PAR LE CONSTRUCTEUR  
(NL) AUTO'S ZONDER DOOR DE FABRIKANT VOORZIENE BEVESTIGINGSPUNTEN  
(P) VIATURAS SEM PONTOS DE FIXAÇÃO DO CONSTRUTOR PRÉ-EXISTENTES  
(H) FELHÉLYEZÉS GYÁRI JELÖLÉS NÉLKÜLI AUTÓKRA  
(PL) SAMOCHODY BEZ PRZEWDZIANYCH PUNKTOW UMOCOWANIA  
(SLO) MODELI Z NEPREDVIDENIM LEŽIŠČEM S STRANI PROIZVAJALCA  
(HR) TVORNIČKI NEPRIPREMLJENI MODELI

**13**

(IT) MODELLI AUTO  
(GB) CARS  
(E) COCHES  
(D) WAGEN  
(F) VOITURES  
(NL) AUTO  
(P) MODELO AUTO  
(H) AUTÓ TIPUS  
(PL) MODELE SAMOCHODÓW  
(SLO) MODELI AVTOMOBILOV  
(HR) MODELI AUTA

(IT) ANTERIORE  
(GB) FRONT  
(E) DELANTERO  
(D) VORDERE  
(F) AVANT  
(NL) VOORSTE G.  
(P) À FRENTE  
(H) ELSŐ RÚD  
(PL) PRZOD  
(SLO) SPREDAJ  
(HR) PREDNJI

(IT) POSTERIORE  
(GB) REAR  
(E) TRASERO  
(D) HINTERE  
(F) ARRIERE  
(NL) ACHTERSTE G.  
(P) ATRÁS  
(H) HÁTSÓ RÚD  
(PL) TYL  
(SLO) ZADAJ  
(HR) STRAŽNJI

(IT) AVVITARE  
(GB) TO SCREW  
(E) APRETAR  
(D) FESTSCHRAUBEN  
(F) VISSER  
(NL) VASTSCHROEVEN  
(P) APERTAR  
(H) MEGHÚZNI  
(PL) WKRECIC  
(SLO) PRIVITI  
(HR) PRIČVRSTITI

5 Nm

(IT) MODELLI AUTO (GB) CARS (E) COCHES (D) WAGEN (F) VOITURES (NL) AUTO (P) MODELO AUTO (H) AUTÓ TIPUS (PL) MODELE SAMOCHODÓW (SLO) MODELI AVTOMOBILOV (HR) MODELI AUTA	(IT) ANTERIORE (GB) FRONT (E) DELANTERO (D) VORDERE (F) AVANT (NL) VOORSTE G. (P) À FRENTE (H) ELSŐ RÚD (PL) PRZOD (SLO) SPREDAJ (HR) PREDNJI	(IT) POSTERIORE (GB) REAR (E) TRASERO (D) HINTERE (F) ARRIERE (NL) ACHTERSTE G. (P) ATRÁS (H) HÁTSÓ RÚD (PL) TYL (SLO) ZADAJ (HR) STRAŽNJI
AUDI A3 (->02)	T (270 mm)	Z (420 mm)
AUDI A3 5P SPORTBACK NO RAILS (03->12)	T (200 mm)	Z (500 mm)
AUDI A6 (04->10)	T (300 mm)	Z (400 mm)
DAEWOO EVANDA	T (200 mm)	Z (400 mm)
DAEWOO KALOS 5P	T (250 mm)	Z (450 mm)
DAEWOO LANOS 4-5P	T (300 mm)	Z (300 mm)
DAEWOO NUBIRA I 4-5P (->02)	T (260 mm)	Z (310 mm)
DAIHATSU SIRION 5P (->05)	T (300 mm)	Z (400 mm)
DAIHATSU TERIOS NO RAILS (06->)	T (300 mm)	Z (400 mm)
FORD FIESTA 5P (08->)	T (200 mm)	Z (500 mm)
HONDA STREAM	T (250 mm)	Z (450 mm)
KIA SHUMA	T (270 mm)	Z (320 mm)
MERCEDES CLASSE A Passo Lungo (->04)	T (180 mm)	Z (520 mm)
PEUGEOT 605	T (350 mm)	Z (350 mm)
RENAULT ESPACE senza predispos. orig. (->96)	T (350 mm)	Z (350 mm)
RENAULT ESPACE senza predispos. orig. (97->04)	T (350 mm)	Z (350 mm)
ROVER 75	T (280 mm)	Z (360 mm)
SEAT ALTEA (05->09) (09->)	T (250 mm)	Z (350 mm)
SEAT TOLEDO (04->09)	T (280 mm)	Z (400 mm)
SUZUKI ALTO 5P (02->09)	T (250 mm)	Z (450 mm)
TOYOTA COROLLA 5P (02->07)	T (250 mm)	Z (450 mm)
VOLVO S40 (96->04)	T (220 mm)	Z (350 mm)
VOLVO S40 (04->12)	T (150 mm)	Z (520 mm)
VOLVO V40 NO RAILS (96->04)	T (280 mm)	Z (320 mm)
VOLVO V50 NO RAILS (04->12)	T (260 mm)	Z (440 mm)

**(IT) Attenzione:** Istruzioni di montaggio per barre in ferro.  
**(GB) Attention:** Mounting instructions for steel bar carriers.  
**(E) Atención:** Instrucciones de montaje para barras portatodo en hierro.  
**(D) Achtung:** Montageanweisungen für Stahl-Lastenträger.  
**(F) Attention:** Notices de montage pour barres de portage en métal.  
**(NL) Attentie:** Handleiding voor dakdragers gemaakt van ijzer.  
**(P) Atenção:** Intruções de montagem para barras de tejadilho em ferro.  
**(H) Szerelési utasítás** acél tartórudakhoz.  
**(PL) Uwaga:** Instrukcja montażu bagażników wykonanych ze stali.  
**(SLO) Pozor:** Navodila za montažo nosilcev prtljažnika-železnih.  
**(HR) Uputstvo za** montažu željeznih krovnih nosača.

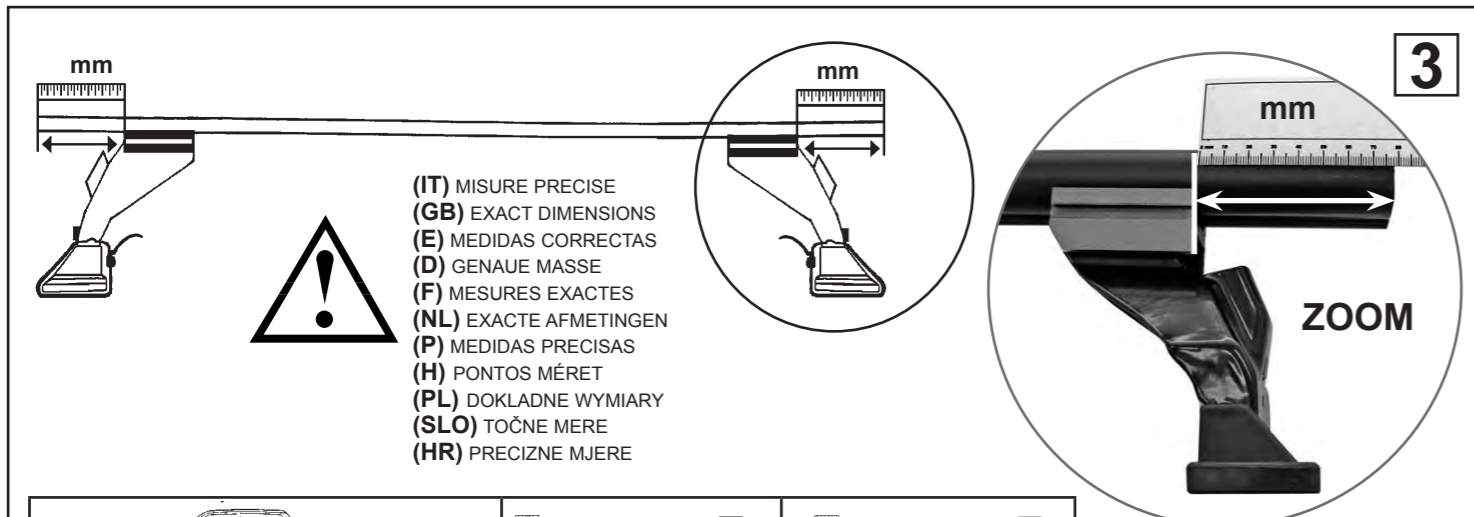
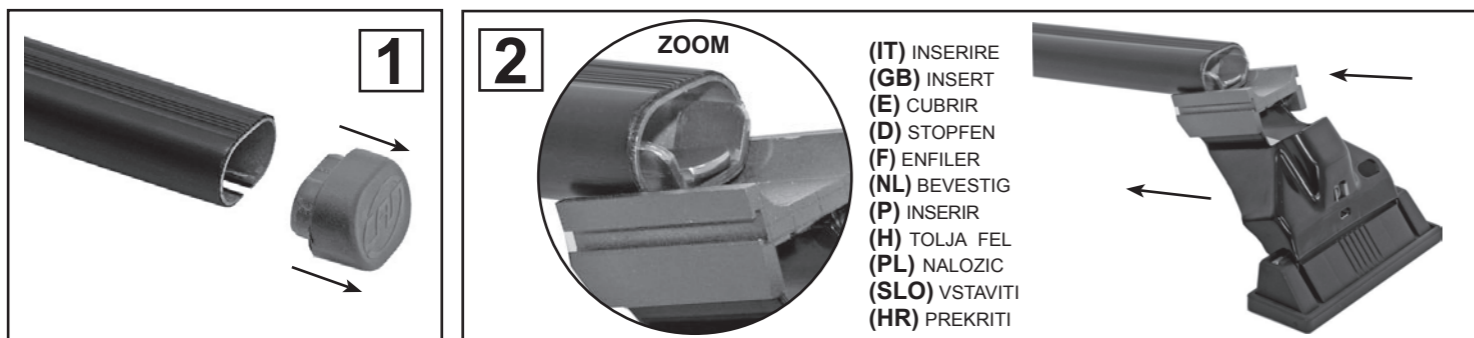

(IT) MODELLI AUTO (NL) AUTO (GB) CARS (P) MODELO AUTO (E) COCHES (H) AUTÓ TIPUS (D) WAGEN (PL) MODELE SAMOCHODÓW (F) VOITURES (SLO) MODELI AVTOMOBILOV (HR) MODELI AUTA	(IT) ANTERIORE (NL) VOORSTE G. (GB) FRONT (P) À FRENTE (E) DELANTERO (H) ELSŐ RÚD (D) VORDERE (PL) PRZOD (F) AVANT (SLO) SPREDAJ (HR) PREDNJI	(IT) POST. (NL) ACHTERSTE G. (GB) REAR (P) ATRÁS (E) TRASERO (H) HÁTSÓ RÚD (D) HINTERE (PL) TYŁ (F) ARRIERE (SLO) ZADAJ (HR) STRAŽNJI
AUDI 80 (86->)	100 mm	111 mm
AUDI 100 (91->)	67 mm	82 mm
AUDI A3 (->02)	67 mm	87 mm
AUDI A3 5P (->02)	71 mm	87 mm
AUDI A3 5P SPORTBACK NO RAILS (03->12)	32 mm	52 mm
AUDI A6 (->96)	35 mm	47 mm
AUDI A6 (97->04)	35 mm	30 mm
AUDI A6 (04->10)	108 mm	106 mm
BMW SERIE 5 (03->10)	98 mm	98 mm
BMW SERIE 5 TOURING NO RAILS (04->10)	99 mm	109 mm
DAEWOO EVANDA	81 mm	91 mm
DAEWOO KALOS 5P	47 mm	61 mm
DAEWOO LANOS 4-5P	86 mm	90 mm
DAEWOO NUBIRA I 4-5P (->02)	70 mm	75 mm
DAIHATSU SIRION 5P (->05)	46 mm	57 mm
DAIHATSU TERIOS NO RAILS (06->)	105 mm	115 mm
FORD FIESTA 5P (08->)	36 mm	47 mm
HONDA ACCORD 5P (95->02)	70 mm	62 mm
HONDA CIVIC 5P (01->06)	45 mm	48 mm
HONDA STREAM	125 mm	130 mm

HYUNDAI ACCENT 4-5 P (00->06)	65 mm	62 mm
KIA SHUMA	71 mm	71 mm
MERCEDES CLASSE A (->04) passo lungo long wheelbase / version lounge / langer Radstand	46 mm	63 mm
PEUGEOT 605	110 mm	110 mm
RENAULT ESPACE (->96) Senza predis. Orig. Without original mounting points Sans points de fixation d'origine Ohne original Befestigungspunkten	75 mm	75 mm
RENAULT ESPACE (97->04) Senza predis. Orig. Without original mounting points Sans points de fixation d'origine Ohne original Befestigungspunkten	69 mm	77 mm
ROVER 600	70 mm	65 mm
ROVER 75	32 mm	32 mm
SEAT ALTEA (05->09)	109 mm	119 mm
SEAT ALTEA (09->)	118 mm	129 mm
SEAT AROSA	54 mm	78 mm
SEAT TOLEDO (04->09)	109 mm	121 mm
SUZUKI ALTO 5P (02->09)	120 mm	136 mm
TOYOTA COROLLA 5P (02->07)	125 mm	110 mm
VOLVO S40 (96->04)	75 mm	81 mm
VOLVO S40 (04->12)	92 mm	87 mm
VOLVO V40 NO RAILS (96->04)	67 mm	87 mm
VOLVO V50 NO RAILS (04->12)	97 mm	103 mm
VW LUPO	48 mm	72 mm
VW PASSAT (88->96)	72 mm	97 mm
VW PASSAT (97->99)	45 mm	45 mm
VW PASSAT (00->05)	37 mm	34 mm
VW PASSAT SW NO RAILS (00->05)	37 mm	43 mm

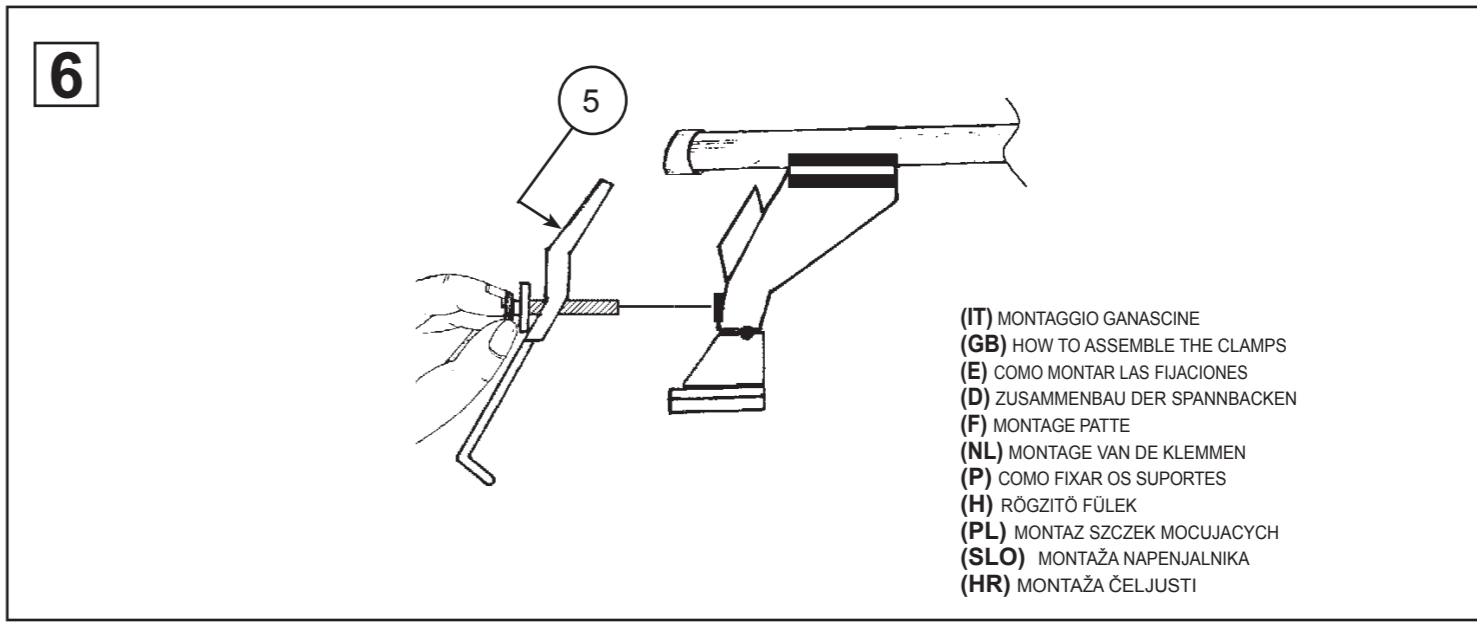
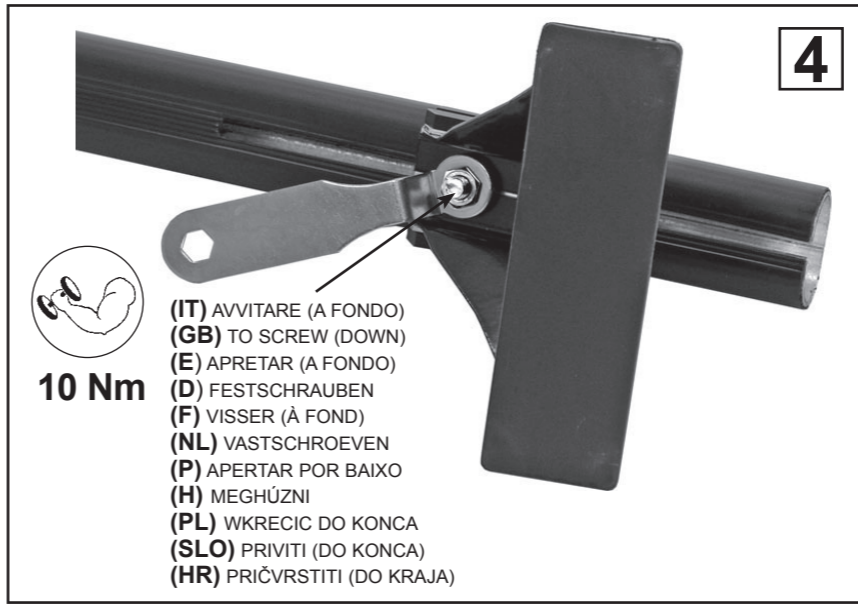

**7**

(IT) PULIRE IL TETTO  
(GB) CLEAN THE ROOF  
(E) LIMPIAR EL TECHO  
(D) DACH REINIGEN  
(F) NETTOYER LE TOIT  
(NL) DAK SCHOONMAKEN  
(P) LIMPAR O TEJADILHO  
(H) TISZTÍTSÁ MEG A TETŐT  
(PL) WYCZYŚCIC DACH  
(SLO) OČISTITI STREHO  
(HR) ČIŠEENJE KROVA

**8**

OPTIMUM  
700 mm

**9**

(IT) CENTRARE IL P. TUTTO SUL TETTO  
(GB) CENTRE THE UNIVERSAL BAR CARRIER ON THE ROOF  
(E) CENTRAR EL PORTAEQUIPAJES SOBRE EL TECHO  
(D) LASTENTRÄGER AUF DEM DACH ZENTRIEREN  
(F) CENTRER LE PORTE-TOUT SUR LE TOIT  
(NL) PLAATS DE UNIVERSELE DRAGER IN HET MIDDEN VAN HET DAK  
(P) CENTRAR AS BARRAS PORTA BAGAGENS NO TEJADILHO  
(H) HELYEZZE KÖZÉPRE A RUDAKAT  
(PL) WYSRODKOWAC BAGAZNIK NA DACHU  
(SLO) CENTRIRATI PRTLJAŽNIK NA STREHO  
(HR) CENTRIRATI NOSAČE NA KROV

OK  
NO

(IT) MODELLI CON PREDISPOSIZIONE DELLA CASA AUTO  
(GB) CARS WITH PRE-EXISTING FIXING POINT FROM MANUFACTURER  
(E) MODELOS CON PREDISPOSICION DEL FABRICANTE  
(D) AUTOS MIT VOM HERSTELLER VORGEGEHENE BEFESTIGUNGSPUNKTE  
(F) VOITURES AVEC POINTS DE RÉPÈRE PRÉVUS PAR LE CONSTRUCTEUR  
(NL) AUTO'S MET DOOR DE FABRIKANT VOORZIENE MONTAGEPUNTEN  
(P) VIATURAS COM PONTOS DE FIXAÇÃO DO CONSTRUTOR PRÉ-EXISTENTES  
(H) FELHELYEZÉS GYÁRTÓ ÁLTAL KIJELÖLT PONTRA  
(PL) SAMOCHODY Z PRZEWIDZIANYMI PUNKTAMI UMOCOWANIA  
(SLO) MODELI Z PREDVIDENIM LEŽIŠČEM S STRANI PROIZVAJALCA  
(HR) TVORNIČKI PRIPREMLJENI MODELI

**10**

“À TROUVER SUR LE BATTANT DE LA PORTE OU DANS LE MANUAL TECHNIQUE DE LA VOITURE “

(IT) MODELLI AUTO (GB) CARS (E) COCHES (D) WAGEN (F) VOITURES (NL) AUTO (P) MODELO AUTO (H) AUTÓ TIPUS (PL) MODELE SAMOCHODÓW (SLO) MODELI AVTOMOBILOV (HR) MODELI AUTA	(IT) ANTERIORE (GB) FRONT (E) DELANTERO (D) VORDERE (F) AVANT (NL) VOORSTE G. (P) À FRENTE (H) ELSŐ RÚD (PL) PRZOD (SLO) SPREDAJ (HR) PREDNJI	(IT) POSTERIORE (GB) REAR (E) TRASERO (D) HINTERE (F) ARRIERE (NL) ACHTERSTE G. (P) ATRÁS (H) HÁTÓSÓ RÚD (PL) TYL (SLO) ZADAJ (HR) STRAŽNJI
AUDI A3 5P (->02)	T	Z
AUDI 80 (86 ->)	T	Z
AUDI 100 (91->)	T	Z
AUDI A6 (->96)	T	Z
AUDI A6 (97->04)	T	Z
BMW SERIE 5 (03->10)	T	Z
BMW SERIE 5 TOURING NO RAILS (04->10)	T	Z
HONDA ACCORD 5P (95->02)	T	Z
HONDA CIVIC 5P (01->06)	T	Z
HYUNDAI ACCENT 4-5 P (00->06)	T	Z
ROVER 600	T	Z
SEAT AROSA	T	Z
VW LUPO	T	Z
VW PASSAT (88->96)	T	Z
VW PASSAT (97->99)	T	Z
VW PASSAT (00->05)	T	Z
VW PASSAT SW NO RAILS (00->05)	T	Z

(IT) AVVITARE  
(GB) TO SCREW  
(E) APRETAR  
(D) FESTSCHRAUBEN  
(F) VISSER  
(NL) VASTSCHROEVEN  
(P) APERTAR  
(H) MEGHÚZNI  
(PL) WKRECIC  
(SLO) PRIVITI  
(HR) PRIČVRSTITI

5 Nm

(IT) MODELLI SENZA PREDISPOSIZIONE DELLA CASA AUTO  
(GB) CARS WITHOUT PRE-EXISTING FIXING POINT  
(E) PARA COCHES SIN PREDISPOSICION DEL FABRICANTE  
(D) AUTOS OHNE VOM HERSTELLER VORGEGEHENE BEFESTIGUNGSPUNKTE  
(F) VOITURES SANS POINTS DE RÉPÈRE PRÉVUS PAR LE CONSTRUCTEUR  
(NL) AUTO'S ZONDER DOOR DE FABRIKANT VOORZIENE BEVESTIGINGSPUNTEN  
(P) VIATURAS SEM PONTOS DE FIXAÇÃO DO CONSTRUTOR PRÉ-EXISTENTES  
(H) FELHELYEZÉS GYÁRI JELÖLÉS NÉLKÜLI AUTÓKRA  
(PL) SAMOCHODY BEZ PRZEWIDZIANYCH PUNKTOW UMOCOWANIA  
(SLO) MODELI Z NEPREDVIDENIM LEŽIŠČEM S STRANI PROIZVAJALCA  
(HR) TVORNIČKI NEPRIPREMLJENI MODELI

**11**

(IT) MODELLI AUTO (GB) CARS (E) COCHES (D) WAGEN (F) VOITURES (NL) AUTO (P) MODELO AUTO (H) AUTÓ TIPUS (PL) MODELE SAMOCHODÓW (SLO) MODELI AVTOMOBILOV (HR) MODELI AUTA	(IT) ANTERIORE (GB) FRONT (E) DELANTERO (D) VORDERE (F) AVANT (NL) VOORSTE G. (P) À FRENTE (H) ELSŐ RÚD (PL) PRZOD (SLO) SPREDAJ (HR) PREDNJI	(IT) POSTERIORE (GB) REAR (E) TRASERO (D) HINTERE (F) ARRIERE (NL) ACHTERSTE G. (P) ATRÁS (H) HÁTÓSÓ RÚD (PL) TYL (SLO) ZADAJ (HR) STRAŽNJI
AUDI A3 (->02)	T (270 mm)	Z (420 mm)
AUDI A3 5P SPORTBACK NO RAILS (03->12)	T (200 mm)	Z (500 mm)
AUDI A6 (04->10)	T (300 mm)	Z (400 mm)
DAEWOO EVANDA	T (200 mm)	Z (400 mm)
DAEWOO KALOS 5P	T (250 mm)	Z (450 mm)
DAEWOO LANOS 4-5P	T (300 mm)	Z (300 mm)
DAEWOO NUBIRA I 4-5P (->02)	T (260 mm)	Z (310 mm)
DAIHATSU SIRION 5P (->05)	T (300 mm)	Z (400 mm)
DAIHATSU TERIOS NO RAILS (06->)	T (300 mm)	Z (400 mm)
FORD FIESTA 5P (08->)	T (200 mm)	Z (500 mm)
HONDA STREAM	T (250 mm)	Z (450 mm)
KIA SHUMA	T (270 mm)	Z (320 mm)
MERCEDES CLASSE A Passo Lungo (->04)	T (180 mm)	Z (520 mm)
PEUGEOT 605	T (350 mm)	Z (350 mm)
RENAULT ESPACE senza predispos. orig. (->96)	T (350 mm)	Z (350 mm)
RENAULT ESPACE senza predispos. orig. (97->04)	T (350 mm)	Z (350 mm)
ROVER 75	T (280 mm)	Z (360 mm)
SEAT ALTEA (05->09) (09->)	T (250 mm)	Z (350 mm)
SEAT TOLEDO (04->09)	T (280 mm)	Z (400 mm)
SUZUKI ALTO 5P (02->09)	T (250 mm)	Z (450 mm)
TOYOTA COROLLA 5P (02->07)	T (250 mm)	Z (450 mm)
VOLVO S40 (96->04)	T (220 mm)	Z (350 mm)
VOLVO S40 (04->12)	T (150 mm)	Z (520 mm)
VOLVO V40 NO RAILS (96->04)	T (280 mm)	Z (320 mm)
VOLVO V50 NO RAILS (04->12)	T (260 mm)	Z (440 mm)

(IT) AVVITARE  
(GB) TO SCREW  
(E) APRETAR  
(D) FESTSCHRAUBEN  
(F) VISSER  
(NL) VASTSCHROEVEN  
(P) APERTAR  
(H) MEGHÚZNI  
(PL) WKRECIC  
(SLO) PRIVITI  
(HR) PRIČVRSTITI

5 Nm

**40005 PARTS LIST**

x4 Cod. VTBS08P30



x4 Cod. 32052/Z



x4 Cod. ROZB08016



x4 Cod. DDFZ08001



x4 Cod. 60328

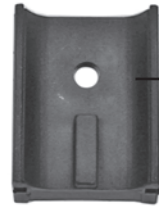

x4 Cod. 32053/Z

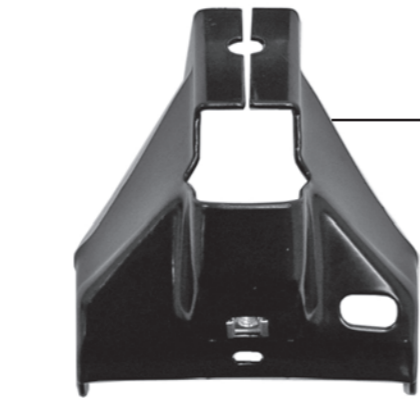
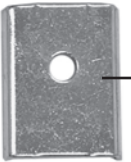

x4 Cod. 31051/V



x4 Cod. 57619



x4 Cod. DDFZ06006



x4 Cod. 60243

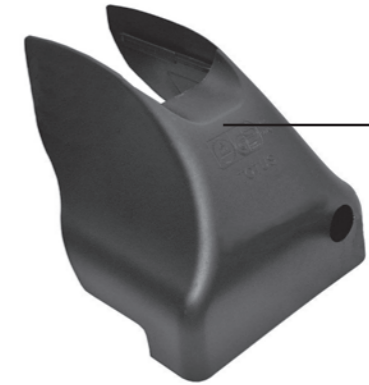

x4 Cod. 60239



x4 Cod. 60263



x1 Cod. 60273

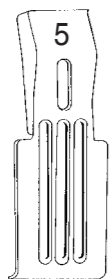

x4 Cod. 31745/V

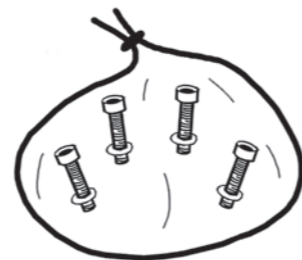

x1 Cod. 37930/M



mm

x1 Cod. 55099



x1 Cod. 32032/Z

# COVER TOTUS

(IT) ISTRUZIONI DI MONTAGGIO (GB) FITTING INSTRUCTIONS (E) INSTRUCCIONES PARA SU MONTAJE  
(D) MONTAGEANWEISUNGEN (F) INSTRUCTIONS DE MONTAGE (NL) MONTAGE INSTRUCTIES (P) INSTRUÇÕES DE MONTAGEM  
(H) SZERELÉSI UTASÍTÁS (PL) INSTRUKCJA MONTAŻU (SLO) NAVODILA O MONTAŽI (HR) UPUTE ZA MONTAŽU.

# 1



(IT) INSERIRE  
(GB) INSERT  
(E) CUBRIR  
(D) STOPFEN  
(F) ENFILER  
(P) INSERIR  
(NL) BEVESTIG  
(H) TOLJA FEL  
(PL) NALOZIC  
(SLO) VSTAVITI  
(HR) PREKRITI



# 2

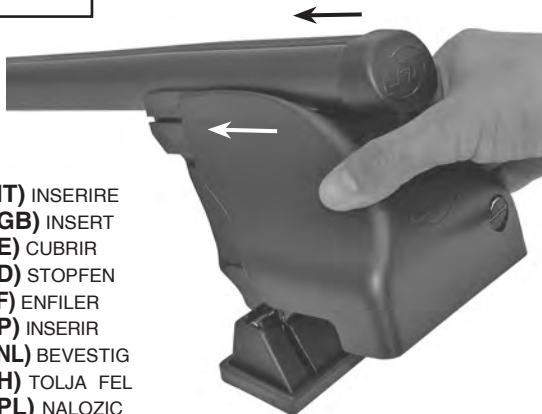

(IT) INSERIRE  
(GB) INSERT  
(E) CUBRIR  
(D) STOPFEN  
(F) ENFILER  
(P) INSERIR  
(NL) BEVESTIG  
(H) TOLJA FEL  
(PL) NALOZIC  
(SLO) VSTAVITI  
(HR) PREKRITI

# 3



# 4



(IT) INSERIRE  
(GB) INSERT  
(E) CUBRIR  
(D) STOPFEN  
(F) ENFILER  
(P) INSERIR  
(NL) BEVESTIG  
(H) TOLJA FEL  
(PL) NALOZIC  
(SLO) VSTAVITI  
(HR) PREKRITI



**NO PER ART. 40102 - 40115 - 40119**