

(IT) Attenzione: Istruzioni di montaggio per barre in alluminio.
(GB) Attention: Mounting instructions for aluminium bar carriers.
(E) Atención: Instrucciones de montaje para barras portatodo en aluminio.
(D) Achtung: Montageanweisungen für Aluminium-Lastenträger.
(F) Attention: Notices de montage pour barres de portage en aluminium.
(NL) Attentie: Handleiding voor dakdragers gemaakt van aluminium.
(P) Atenção: Instruções de montagem para barras de tejadilho em alumínio.
(H) Szerelési utasítás alumínium tartórudakhoz.
(PL) Uwaga: Instrukcja montażu bagażników wykonanych ze aluminium.
(SLO) Pozor: Navodila za montažo nosilcev prtljažnika - aluminijastih.
(HR) Uputstvo za montažu aluminijaskih nosača.

1

ZOOM

(A)

(B)

(C)

(D)

(IT) SVITARE
(GB) UNSCREW
(E) AFLOJAR
(D) ABSCHRAUBEN
(F) DEVISSER
(NL) OPENSCHROEVEN
(P) DESAPARAFUSAR
(H) KICSAVARNI
(PL) WYKRECIC
(SLO) ODVITI
(HR) ODVITI

(IT) INSERIRE
(GB) INSERT
(E) CUBRIR
(D) STOPFEN
(F) ENFILER
(NL) BEVESTIG

(P) INSERIR
(H) TOLJA FEL
(PL) NALOZIC
(SLO) VSTAVITI
(HR) PREKRITI

(IT) AVVITARE
(GB) TO SCREW
(E) APRETAR
(D) FESTSCHRAUBEN
(F) VISSER
(NL) VASTSCHROEVEN

(P) APERTAR
(H) MEGHÚZNI
(PL) WKRECIC
(SLO) PRIVITI
(HR) PRIČVRSTITI

2

ZOOM

(IT) INSERIRE
(GB) INSERT
(E) CUBRIR
(D) STOPFEN
(F) ENFILER
(NL) BEVESTIG

(P) INSERIR
(H) TOLJA FEL
(PL) NALOZIC
(SLO) VSTAVITI
(HR) PREKRITI

3

(IT) MODELLI AUTO (GB) CARS (E) COCHES (D) WAGEN (F) VOITURES	(NL) AUTO (P) MODELO AUTO (H) AUTÓ TIPUS (PL) MODELE SAMOCHODÓW (SLO) MODELI AVTOMOBILOV (HR) MODELI AUTA	(IT) ANTERIORE (GB) FRONT (E) DELANTERO (D) VORDERE (F) AVANT	(NL) VOORSTE G. (P) À FRENTE (H) ELSŐ RÚD (PL) PRZOD (SLO) SPREDAJ (HR) PREDNJI	(IT) POST. (GB) REAR (E) TRASERO (D) HINTERE (F) ARRIERE	(NL) ACHTERSTE G. (P) ATRÁS (H) HÁTSÓ RÚD (PL) TYŁ (SLO) ZADAJ (HR) STRAŽNJI
ALFA ROMEO 75		112 mm		127 mm	
BMW SERIE 5 (91->95)		120 mm		120 mm	
BMW SERIE 5 (96->02)		132 mm		132 mm	
DAIHATSU CUORE 5P (03->06)		157 mm		151 mm	
HYUNDAI ACCENT 5P (07->)		122 mm		138 mm	
HYUNDAI ATOS PRIME NO RAILS		57 mm		58 mm	
HONDA FR-V NO RAILS		77 mm		92 mm	
HONDA JAZZ (08->) Con e senza tetto in vetro / With and without glass roof / Avec et sauf toit en verre / Mit und ohne Glasdach		118 mm		141 mm	
KIA PICANTO (->10)		155 mm		142 mm	
LEXUS IS 200 (98->06)		127 mm		127 mm	
MERCEDES 190		127 mm		137 mm	
MERCEDES 200		105 mm		105 mm	
MERCEDES SERIE C (->00)		115 mm		127 mm	
MERCEDES SERIE C (01->07)		117 mm		128 mm	
MERCEDES SERIE E (->01)		102 mm		102 mm	
MERCEDES SERIE E (02->09)		106 mm		120 mm	
RENAULT LAGUNA I (94->00)		140 mm		155 mm	
SKODA SUPERB		125 mm		125 mm	
TOYOTA AVENSIS (->03)		157 mm		157 mm	
TOYOTA AVENSIS (03->09)		106 mm		112 mm	
TOYOTA CARINA		142 mm		158 mm	
TOYOTA COROLLA VERSO (01->04)		111 mm		117 mm	

(IT) MISURE PRECISE
(GB) EXACT DIMENSIONS
(E) MEDIDAS CORRECTAS
(D) GENAU MASSE
(F) MESURES EXACTES
(NL) EXACTE AFMETINGEN

(P) MEDIDAS PRECISAS
(H) PONTOS MÉRET
(PL) DOKŁADNE WYMIARY
(SLO) TOČNE MERE
(HR) PRECIZNE MJERE

ZOOM

(IT) TAGLIARE
(GB) TO CUT
(E) CORTAR
(D) SCHNEIDEN
(F) COUPER
(NL) SNIJDEN
(P) CORTAR
(H) ELVÁGNI
(PL) OBCIAC
(SLO) ODREZATI
(HR) ODREZATI

(IT) INSERIRE
(GB) INSERT
(E) CUBRIR
(D) STOPFEN
(F) ENFILER
(NL) BEVESTIG

(P) INSERIR
(H) TOLJA FEL
(PL) NALOZIC
(SLO) VSTAVITI
(HR) PREKRITI

4

(IT) AVVITARE (A FONDO)
(GB) TO SCREW (DOWN)
(E) APRETAR (A FONDO)
(D) FESTSCHRAUBEN
(F) VISSER (À FOND)
(NL) VASTSCHROEVEN
(P) APERTAR POR BAIXO
(H) MEGHÚZNI
(PL) WKRECIC DO KONCA
(SLO) PRIVITI (DO KONCA)
(HR) PRIČVRSTITI (DO KRAJA)

10 Nm

5

(IT) INSERIRE
(GB) INSERT
(E) CUBRIR
(D) STOPFEN
(F) ENFILER
(P) INSERIR
(NL) BEVESTIG
(H) TOLJA FEL
(PL) NALOZIC
(SLO) VSTAVITI
(HR) PREKRITI

6

(IT) TAGLIARE
(GB) TO CUT
(E) CORTAR
(D) SCHNEIDEN
(F) COUPER
(NL) SNIJDEN
(P) CORTAR
(H) ELVÁGNI
(PL) OBCIAC
(SLO) ODREZATI
(HR) ODREZATI

(IT) INSERIRE
(GB) INSERT
(E) CUBRIR
(D) STOPFEN
(F) ENFILER
(P) INSERIR
(NL) BEVESTIG
(H) TOLJA FEL
(PL) NALOZIC
(SLO) VSTAVITI
(HR) PREKRITI

7

(IT) INSERIRE
(GB) INSERT
(E) CUBRIR
(D) STOPFEN
(F) ENFILER
(NL) BEVESTIG

(P) INSERIR
(H) TOLJA FEL
(PL) NALOZIC
(SLO) VSTAVITI
(HR) PREKRITI

(IT) TAGLIARE
(GB) TO CUT
(E) CORTAR
(D) SCHNEIDEN
(F) COUPER
(NL) SNIJDEN
(P) CORTAR
(H) ELVÁGNI
(PL) OBCIAC
(SLO) ODREZATI
(HR) ODREZATI

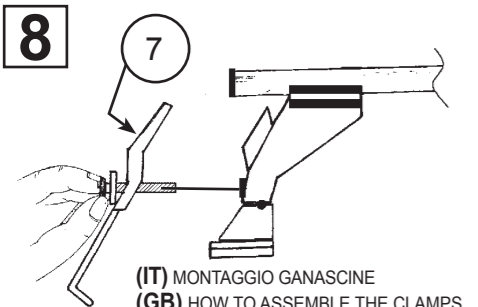

8

(IT) MONTAGGIO GANASCINE
 (GB) HOW TO ASSEMBLE THE CLAMPS
 (E) COMO MONTAR LAS FIJACIONES
 (D) ZUSAMMENBAU DER SPANNBACKEN
 (F) MONTAGE PATTE
 (NL) MONTAGE VAN DE KLEMMEN
 (P) COMO FIXAR OS SUPORTES
 (H) RÖGZITŐ FÜLEK
 (PL) MONTAZ SZCZEK MOCUJACYCH
 (SLO) MONTAŽA NAPENJALNIKA
 (HR) MONTAŽA ČELJUSTI

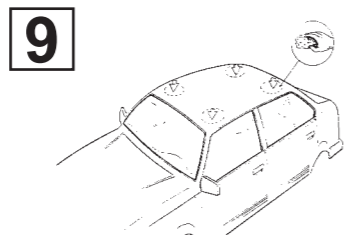

9

(IT) PULIRE IL TETTO
 (GB) CLEAN THE ROOF
 (E) LIMPIAR EL TECHO
 (D) DACH REINIGEN
 (F) NETTOYER LE TOIT
 (NL) DAK SCHOONMAKEN
 (P) LIMPAR O TEJADILHO
 (H) TISZTÍTSA MEG A TETŐT
 (PL) WYCZYSZC DACH
 (SLO) OČISTITI STREHO
 (HR) ČIŠĆENJE KROVA

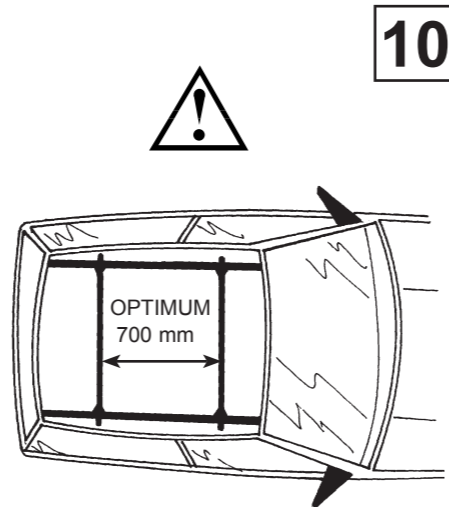

10

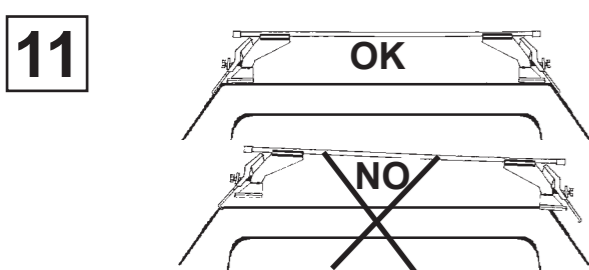

11

(IT) CENTRARE IL P. TUTTO SUL TETTO
 (GB) CENTRE THE UNIVERSAL BAR CARRIER ON THE ROOF
 (E) CENTRAR EL PORTAEQUIPAJES SOBRE EL TECHO
 (D) LASTENTRÄGER AUF DEM DACH ZENTRIEREN
 (F) CENTRER LE PORTE-TOUT SUR LE TOIT
 (NL) PLAATS DE UNIVERSELE DRAGER IN HET MIDDEN VAN HET DAK
 (P) CENTRAR AS BARRAS PORTA BAGAGENS NO TEJADILHO
 (H) HELYEZZE KÖZÉPRE A RUDAKAT
 (PL) WYSRODKOWAC BAGAZNIK NA DACHU
 (SLO) CENTRIRATI PRTLJAŽNIK NA STREHO
 (HR) CENTRIRATI NOSAČE NA KROV

(IT) MODELLI CON PREDISPOSIZIONE DELLA CASA AUTO
 (GB) CARS WITH PRE-EXISTING FIXING POINT FROM MANUFACTURER
 (E) MODELOS CON PREDISPOSICION DEL FABRICANTE
 (D) AUTOS MIT VOM HERSTELLER VORGESEHENE BEFESTIGUNGSPUNKTE
 (F) VOITURES AVEC POINTS DE RÉPÈRE PRÉVUS PAR LE CONSTRUCTEUR
 (NL) AUTO'S MET DOOR DE FABRIKANT VOORZIENE MONTAGEPUNTEN
 (P) VIATURAS COM PONTOS DE FIXAÇÃO DO CONSTRUTOR PRÉ-EXISTENTES
 (H) FELHELYEZÉS GYÁRTÓ ÁLTAL KIJELÖLT PONTRA
 (PL) SAMOCHODY Z PRZEWDZIANYMI PUNKTAMI UMOCOWANIA
 (SLO) MODELI Z PREDVIDENIM LEŽIŠČEM S STRANI PROIZVAJALCA
 (HR) TVORNIČKI PRIPREMLJENI MODELI

“À TROUVER SUR LE BATTANT DE LA PORTE OU DANS LE MANUAL TECHNIQUE DE LA VOITURE “

12

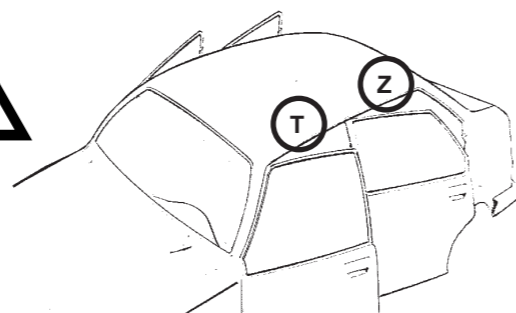

(IT) AVVITARE
 (GB) TO SCREW
 (E) APRETAR
 (D) FESTSCHRAUBEN
 (F) VISSER
 (NL) VASTSCHROEVEN
 (P) APERTAR
 (H) MEGHÚZNI
 (PL) WKRECIC
 (SLO) PRIVITI
 (HR) PRIČVRSTITI

5 Nm

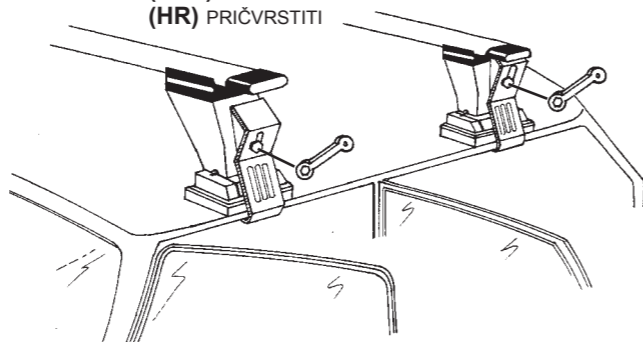

(IT) MODELLI AUTO (GB) CARS (E) COCHES (D) WAGEN (F) VOITURES (NL) AUTO (P) MODELO AUTO (H) AUTÓ TIPUS (PL) MODELE SAMOCHODÓW (SLO) MODELI AVTOMOBILOV (HR) MODELI AUTA	(IT) ANTERIORE (GB) FRONT (E) DELANTERO (D) VORDERE (F) AVANT (NL) VOORSTE G. (P) À FRENTE (H) ELSŐ RÚD (PL) PRZOD (SLO) SPREDAJ (HR) PREDNJI	(IT) POSTERIORE (GB) REAR (E) TRASERO (D) HINTERE (F) ARRIERE (NL) ACHTERSTE G. (P) ATRÁS (H) HÁTSÓ RÚD (PL) TYL (SLO) ZADAJ (HR) STRAŽNJI
HYUNDAI ACCENT 5P (07->)	T	Z
HONDA FR-V NO RAILS	T	Z
HONDA JAZZ (08->) con e senza tetto in vetro	T	Z
LEXUS IS 200 (98->06)	T	Z
MERCEDES 190	T	Z
MERCEDES 200	T	Z
MERCEDES SERIE C (->00)	T	Z
MERCEDES SERIE E (->01)	T	Z
RENAULT LAGUNA (94->00)	T	Z
SKODA SUPERB	T	Z
TOYOTA AVENSIS (->03)	T	Z
TOYOTA AVENSIS (03->09)	T	Z
TOYOTA CARINA	T	Z
TOYOTA COROLLA VERSO (01->04)	T	Z

(IT) MODELLI SENZA PREDISPOSIZIONE DELLA CASA AUTO
 (GB) CARS WITHOUT PRE-EXISTING FIXING POINT
 (E) PARA COCHES SIN PREDISPOSICION DEL FABRICANTE
 (D) AUTOS OHNE VOM HERSTELLER VORGESEHENE BEFESTIGUNGSPUNKTE
 (F) VOITURES SANS POINTS DE RÉPÈRE PRÉVUS PAR LE CONSTRUCTEUR
 (NL) AUTO'S ZONDER DOOR DE FABRIKANT VOORZIENE BEVESTIGINGSPUNTEN
 (P) VIATURAS SEM PONTOS DE FIXAÇÃO DO CONSTRUTOR PRÉ-EXISTENTES
 (H) FELHELYEZÉS GYÁRI JELÖLÉS NÉLKÜLI AUTÓKRA
 (PL) SAMOCHODY BEZ PRZEWDZIANYCH PUNKTOW UMOCOWANIA
 (SLO) MODELI Z NEPREDVIDENIM LEŽIŠČEM S STRANI PROIZVAJALCA
 (HR) TVORNIČKI NEPRIPREMLJENI MODELI

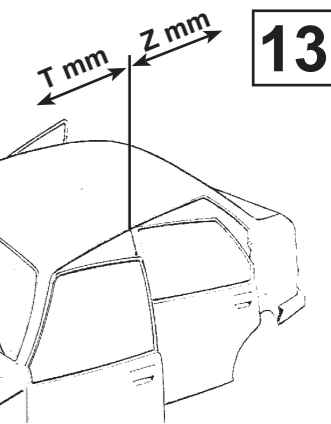

13

(IT) AVVITARE
 (GB) TO SCREW
 (E) APRETAR
 (D) FESTSCHRAUBEN
 (F) VISSER
 (NL) VASTSCHROEVEN
 (P) APERTAR
 (H) MEGHÚZNI
 (PL) WKRECIC
 (SLO) PRIVITI
 (HR) PRIČVRSTITI

5 Nm

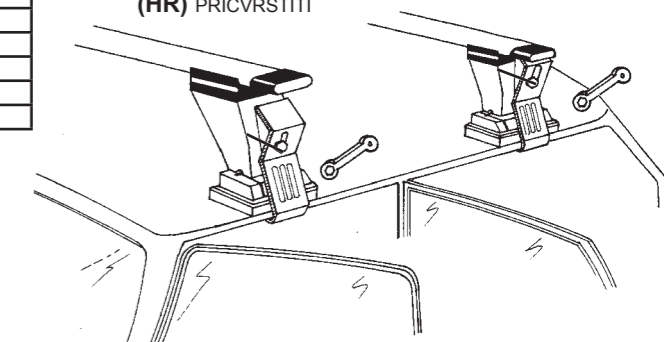

(IT) MODELLI AUTO (GB) CARS (E) COCHES (D) WAGEN (F) VOITURES (NL) AUTO (P) MODELO AUTO (H) AUTÓ TIPUS (PL) MODELE SAMOCHODÓW (SLO) MODELI AVTOMOBILOV (HR) MODELI AUTA	(IT) ANTERIORE (GB) FRONT (E) DELANTERO (D) VORDERE (F) AVANT (NL) VOORSTE G. (P) À FRENTE (H) ELSŐ RÚD (PL) PRZOD (SLO) SPREDAJ (HR) PREDNJI	(IT) POSTERIORE (GB) REAR (E) TRASERO (D) HINTERE (F) ARRIERE (NL) ACHTERSTE G. (P) ATRÁS (H) HÁTSÓ RÚD (PL) TYL (SLO) ZADAJ (HR) STRAŽNJI
ALFA ROMEO 75	T (250 mm)	Z (450 mm)
BMW SERIE 5 (91->95)	T (350 mm)	Z (350 mm)
BMW SERIE 5 (96->02)	T (250 mm)	Z (450 mm)
DAIHATSU CUORE 5P (03->06)	T (250 mm)	Z (450 mm)
HYUNDAI ATOS PRIME NO RAILS	T (250 mm)	Z (400 mm)
KIA PICANTO (->10)	T (250 mm)	Z (500 mm)
MERCEDES SERIE C (01->07)	T (200 mm)	Z (300 mm)
MERCEDES SERIE E (02->09)	T (230 mm)	Z (370 mm)

(IT) Attenzione: Istruzioni di montaggio per barre in ferro.
(GB) Attention: Mounting instructions for steel bar carriers.
(E) Atención: Instrucciones de montaje para barras portatodo en hierro.
(D) Achtung: Montageanweisungen für Stahl-Lastenträger.
(F) Attention: Notices de montage pour barres de portage en métal.
(NL) Attentie: Handleiding voor dakdragers gemaakt van ijzer.
(P) Atenção: Instrukções de montagem para barras de tejadilho em ferro.
(H) Szerelési utasítás acél tartórudakhoz.
(PL) Uwaga: Instrukcja montażu bagażników wykonanych ze stali.
(SLO) Pozor: Navodila za montažo nosilcev prtljažnika-železnih.
(HR) Uputstvo za montažu željeznih krovnih nosača.

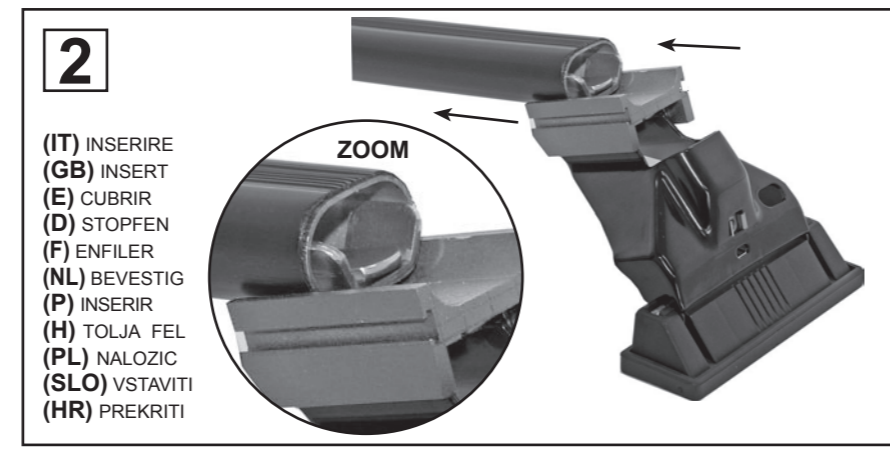
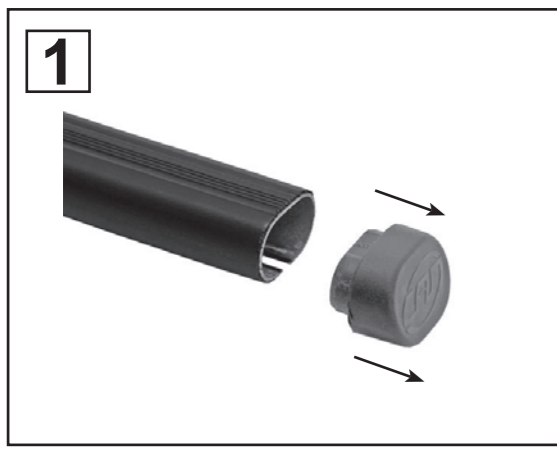

	(IT) ANTERIORE (GB) FRONT (E) DELANTERO (D) VORDERE (F) AVANT	(NL) VOORSTE G. (P) À FRENTE (H) ELSŐ RÜD (PL) PRZOD (SLO) SPREDAJ (HR) PREDNJI	(IT) POST. (GB) REAR (E) TRASERO (D) HINTERE (F) ARRIERE	(NL) ACHTERSTE G. (P) ATRÁS (H) HÁTSÓ RÜD (PL) TYŁ (SLO) ZADAJ (HR) STRAŽNJI
ALFA ROMEO 75	112 mm		127 mm	
BMW SERIE 5 (91->95)	120 mm		120 mm	
BMW SERIE 5 (96->02)	132 mm		132 mm	
DAIHATSU CUORE 5P (03->06)	157 mm		151 mm	
HYUNDAI ACCENT 5P (07->)	122 mm		138 mm	
HYUNDAI ATOS PRIME NO RAILS	57 mm		58 mm	
HONDA FR-V NO RAILS	77 mm		92 mm	
HONDA JAZZ (08->) Con e senza tetto in vetro / With and without glass roof / Avec et sauf toit en verre / Mit und ohne Glasdach	118 mm		141 mm	
KIA PICANTO (->10)	155 mm		142 mm	
LEXUS IS 200 (98->06)	127 mm		127 mm	
MERCEDES 190	127 mm		137 mm	
MERCEDES 200	105 mm		105 mm	
MERCEDES SERIE C (->00)	115 mm		127 mm	
MERCEDES SERIE C (01->07)	117 mm		128 mm	
MERCEDES SERIE E (->01)	102 mm		102 mm	
MERCEDES SERIE E (02->09)	106 mm		120 mm	
RENAULT LAGUNA I (94->00)	140 mm		155 mm	
SKODA SUPERB	125 mm		125 mm	
TOYOTA AVENSIS (->03)	157 mm		157 mm	
TOYOTA AVENSIS (03->09)	106 mm		112 mm	
TOYOTA CARINA	142 mm		158 mm	
TOYOTA COROLLA VERSO (01->04)	111 mm		117 mm	

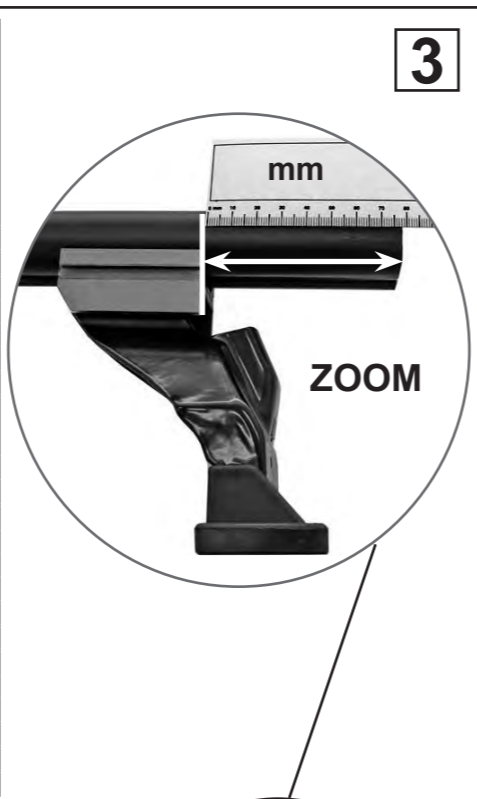

(IT) MISURE PRECISE
(GB) EXACT DIMENSIONS
(E) MEDIDAS CORRECTAS
(D) GENAUE MASSE
(F) MESURES EXACTES
(NL) EXACTE AFMETINGEN
(P) MEDIDAS PRECISAS
(H) PONTOS MÉRET
(PL) DOKŁADNE WYMIARY
(SLO) TOČNE MERE
(HR) PRECIZNE MJERE

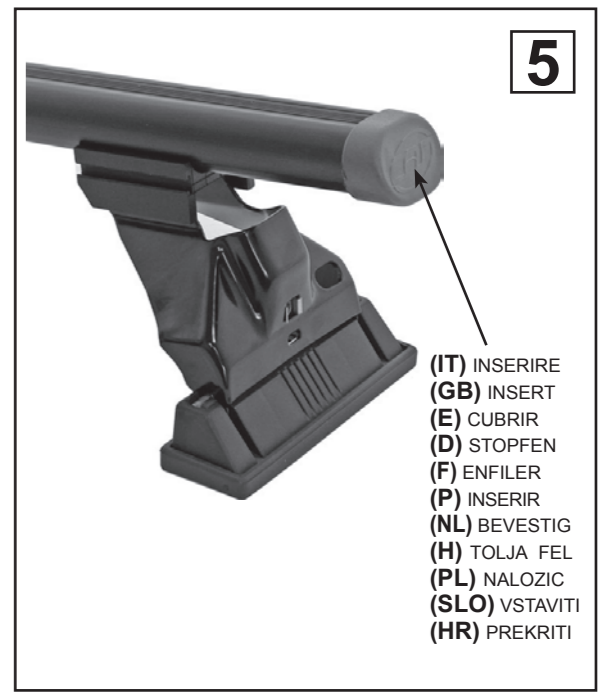
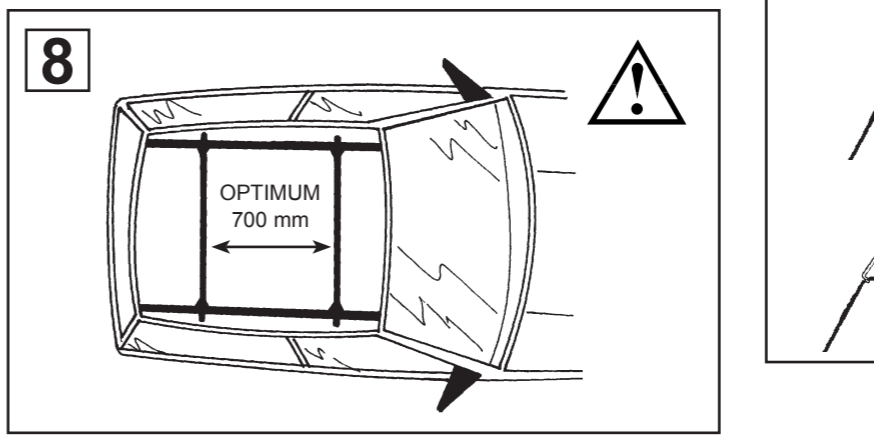
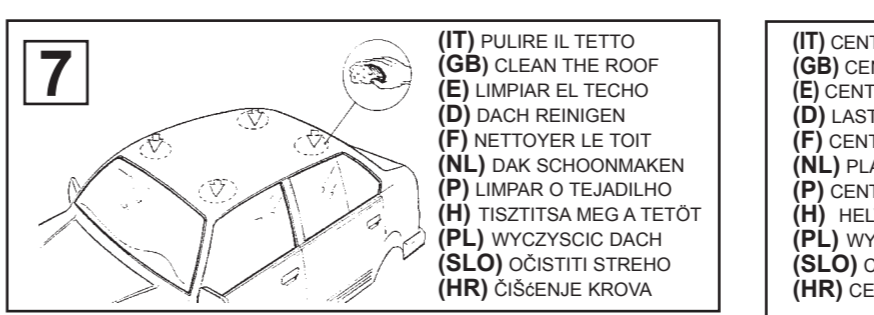
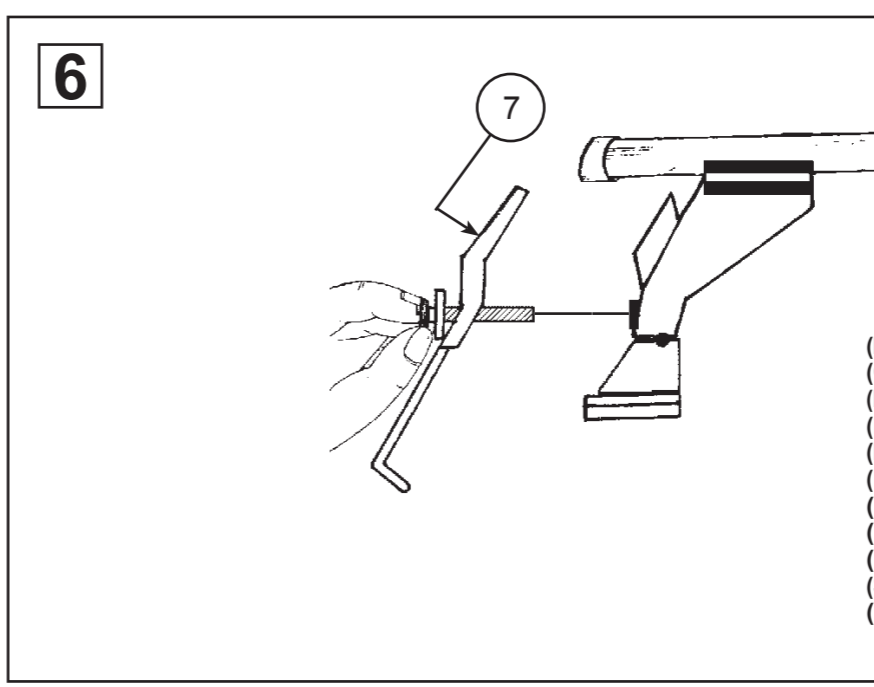
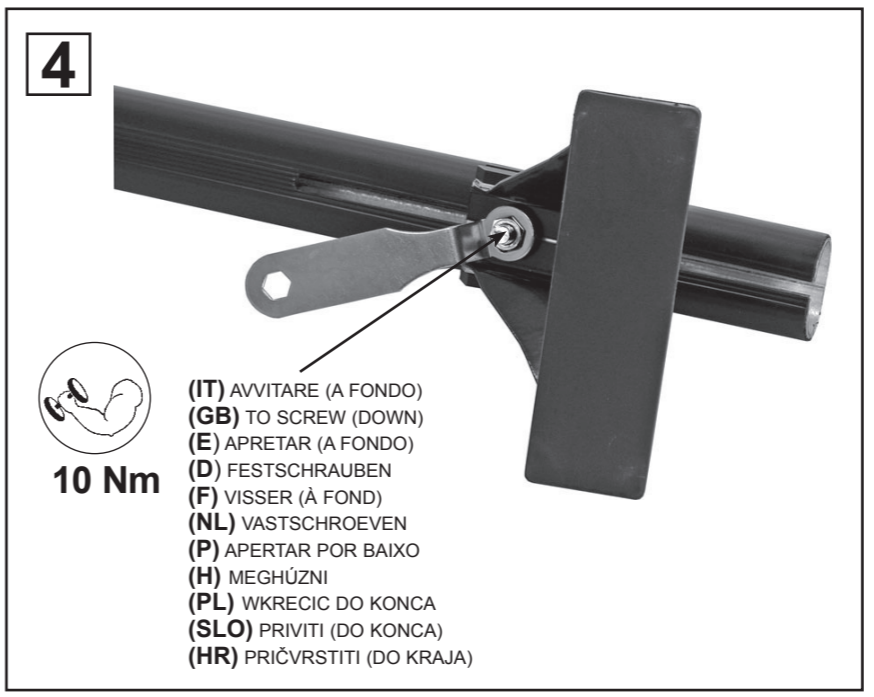

(IT) CENTRARE IL P. TUTTO SUL TETTO
(GB) CENTRE THE UNIVERSAL BAR CARRIER ON THE ROOF
(E) CENTRAR EL PORTAEQUIPAJES SOBRE EL TECHO
(D) LASTENTRÄGER AUF DEM DACH ZENTRIEREN
(F) CENTRER LE PORTE-TOUT SUR LE TOIT
(NL) PLAATS DE UNIVERSELE DRAGER IN HET MIDDEN VAN HET DAK
(P) CENTRAR AS BARRAS PORTA BAGAGENS NO TEJADILHO
(H) HELYEZZE KÖZÉPRE A RUDAKAT
(PL) WYSRODKOWAC BAGAZNIK NA DACHU
(SLO) CENTRIRATI PRTLJAŽNIK NA STREHO
(HR) CENTRIRATI NOSAČE NA KROV

- (IT) MODELLI CON PREDISPOSIZIONE DELLA CASA AUTO
 (GB) CARS WITH PRE-EXISTING FIXING POINT FROM MANUFACTURER
 (E) MODELOS CON PREDISPOSICION DEL FABRICANTE
 (D) AUTOS MIT VOM HERSTELLER VORGESEHENE BEFESTIGUNGSPUNKTE
 (F) VOITURES AVEC POINTS DE RÉPÈRE PREVUS PAR LE CONSTRUCTEUR
 (NL) AUTO'S MET DOOR DE FABRIKANT VOORZIENE MONTAGEPUNTEN
 (P) VIATURAS COM PONTOS DE FIXAÇÃO DO CONSTRUTOR PRÉ-EXISTENTES
 (H) FELHÉLYEZÉS GYÁRTÓ ÁLTAL KIJELÖLT PONTRA
 (PL) SAMOCHODY Z PRZEWIDZIANYMI PUNKTAMI UMOCOWANIA
 (SLO) MODELI Z PREDVIDENIM LEŽIŠČEM S STRANI PROIZVAJALCA
 (HR) TVORNIČKI PRIPREMLJENI MODELI

“À TROUVER SUR LE BATTANT DE LA PORTE OU
 DANS LE MANUAL TECHNIQUE DE LA VOITURE “

10

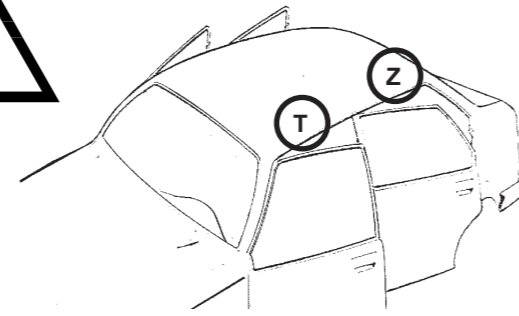

(IT) MODELLI AUTO (GB) CARS (E) COCHES (D) WAGEN (F) VOITURES (NL) AUTO (P) MODELO AUTO (H) AUTÓ TIPUS (PL) MODELE SAMOCHODÓW (SLO) MODELI AVTOMOBILOV (HR) MODELI AUTA	(IT) ANTERIORE (GB) FRONT (E) DELANTERO (D) VORDERE (F) AVANT (NL) VOORSTE G. (P) À FRENTE (H) ELSÓ RÚD (PL) PRZOD (SLO) SPREDAJ (HR) PREDNJI	(IT) POSTERIORE (GB) REAR (E) TRASERO (D) HINTERE (F) ARRIERE (NL) ACHTERSTE G. (P) ATRÁS (H) HÁTSÓ RÚD (PL) TYŁ (SLO) ZADAJ (HR) STRAŽNJI
HYUNDAI ACCENT 5P (07->)	T	Z
HONDA FR-V NO RAILS	T	Z
HONDA JAZZ (08->) con e senza tetto in vetro	T	Z
LEXUS IS 200 (98->06)	T	Z
MERCEDES 190	T	Z
MERCEDES 200	T	Z
MERCEDES SERIE C (->00)	T	Z
MERCEDES SERIE E (->01)	T	Z
RENAULT LAGUNA I (94->00)	T	Z
SKODA SUPERB	T	Z
TOYOTA AVENSIS (->03)	T	Z
TOYOTA AVENSIS (03->09)	T	Z
TOYOTA CARINA	T	Z
TOYOTA COROLLA VERSO (01->04)	T	Z

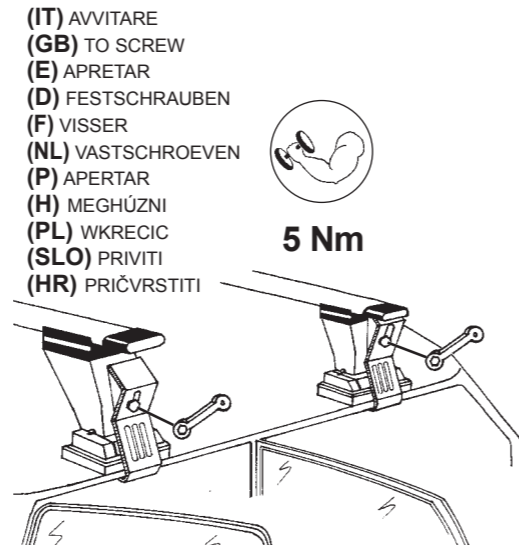

- (IT) AVVITARE
 (GB) TO SCREW
 (E) APRETAR
 (D) FESTSCHRAUBEN
 (F) VISSER
 (NL) VASTSCHROEVEN
 (P) APERTAR
 (H) MEGHÚZNI
 (PL) WKRECIC
 (SLO) PRIVITI
 (HR) PRIČVRSTITI



5 Nm

- (IT) MODELLI SENZA PREDISPOSIZIONE DELLA CASA AUTO
 (GB) CARS WITHOUT PRE-EXISTING FIXING POINT
 (E) PARA COCHES SIN PREDISPOSICION DEL FABRICANTE
 (D) AUTOS OHNE VOM HERSTELLER VORGESEHENE BEFESTIGUNGSPUNKTE
 (F) VOITURES SANS POINTS DE RÉPÈRE PRÉVUS PAR LE CONSTRUCTEUR
 (NL) AUTO'S ZONDER DOOR DE FABRIKANT VOORZIENE BEVESTIGINGSPUNTEN
 (P) VIATURAS SEM PONTOS DE FIXAÇÃO DO CONSTRUTOR PRÉ-EXISTENTES
 (H) FELHÉLYEZÉS GYÁRI JELÖLÉS NÉLKÜLI AUTÓKRA
 (PL) SAMOCHODY BEZ PRZEWIDZIANYCH PUNKTOW UMOCOWANIA
 (SLO) MODELI Z NEPREDVIDENIM LEŽIŠČEM S STRANI PROIZVAJALCA
 (HR) TVORNIČKI NEPRIPREMLJENI MODELI

11

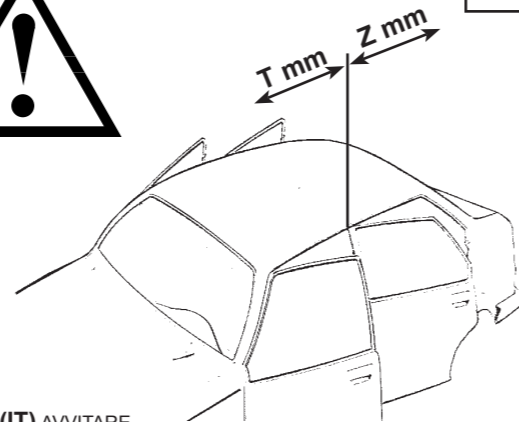

(IT) MODELLI AUTO (GB) CARS (E) COCHES (D) WAGEN (F) VOITURES (NL) AUTO (P) MODELO AUTO (H) AUTÓ TIPUS (PL) MODELE SAMOCHODÓW (SLO) MODELI AVTOMOBILOV (HR) MODELI AUTA	(IT) ANTERIORE (GB) FRONT (E) DELANTERO (D) VORDERE (F) AVANT (NL) VOORSTE G. (P) À FRENTE (H) ELSÓ RÚD (PL) PRZOD (SLO) SPREDAJ (HR) PREDNJI	(IT) POSTERIORE (GB) REAR (E) TRASERO (D) HINTERE (F) ARRIERE (NL) ACHTERSTE G. (P) ATRÁS (H) HÁTSÓ RÚD (PL) TYŁ (SLO) ZADAJ (HR) STRAŽNJI
ALFA ROMEO 75	T (250 mm)	Z (450 mm)
BMW SERIE 5 (91->95)	T (350 mm)	Z (350 mm)
BMW SERIE 5 (96->02)	T (250 mm)	Z (450 mm)
DAIHATSU CUORE 5P (03->06)	T (250 mm)	Z (450 mm)
HYUNDAI ATOS PRIME NO RAILS	T (250 mm)	Z (400 mm)
KIA PICANTO (->10)	T (250 mm)	Z (500 mm)
MERCEDES SERIE C (01->07)	T (200 mm)	Z (300 mm)
MERCEDES SERIE E (02->09)	T (230 mm)	Z (370 mm)

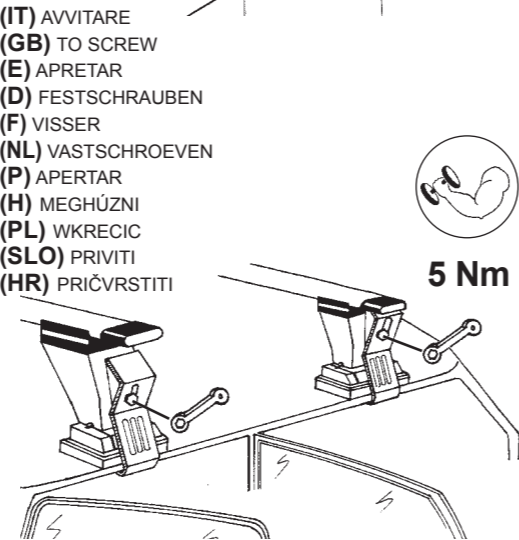

- (IT) AVVITARE
 (GB) TO SCREW
 (E) APRETAR
 (D) FESTSCHRAUBEN
 (F) VISSER
 (NL) VASTSCHROEVEN
 (P) APERTAR
 (H) MEGHÚZNI
 (PL) WKRECIC
 (SLO) PRIVITI
 (HR) PRIČVRSTITI



5 Nm

40007 PARTS LIST

x4 Cod. VTBS08P30



x4 Cod. 32052/Z



x4 Cod. ROZB08016



x4 Cod. DDFZ08001



x4 Cod. 60328

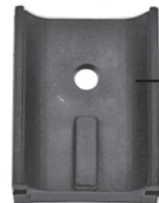

x4 Cod. 32053/Z

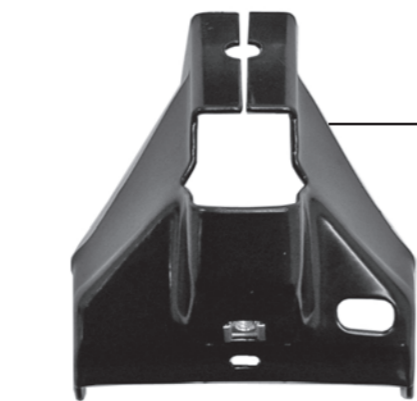
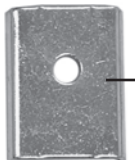

x4 Cod. 31051/V



x4 Cod. DDFZ06006



x4 Cod. 57619



x4 Cod. 60243

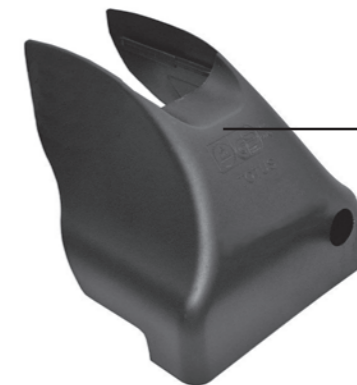

x4 Cod. 60239



x4 Cod. 60263



x1 Cod. 60273

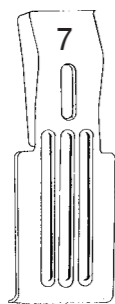

x4 Cod. 31748/V

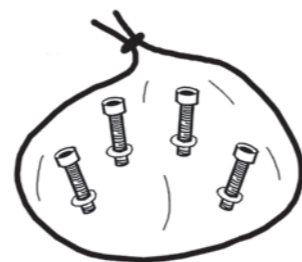

x1 Cod. 37930/M



mm

x1 Cod. 55099



x1 Cod. 32032/Z

COVER TOTUS

(IT) ISTRUZIONI DI MONTAGGIO (GB) FITTING INSTRUCTIONS (E) INSTRUCCIONES PARA SU MONTAJE
(D) MONTAGEANWEISUNGEN (F) INSTRUCTIONS DE MONTAGE (NL) MONTAGE INSTRUCTIES (P) INSTRUÇÕES DE MONTAGEM
(H) SZERELÉSI UTASÍTÁS (PL) INSTRUKCJA MONTAZU (SLO) NAVODILA O MONTAŽI (HR) UPUTE ZA MONTAŽU.

1



(IT) INSERIRE
(GB) INSERT
(E) CUBRIR
(D) STOPFEN
(F) ENFILER
(P) INSERIR
(NL) BEVESTIG
(H) TOLJA FEL
(PL) NALOZIC
(SLO) VSTAVITI
(HR) PREKRITI



2

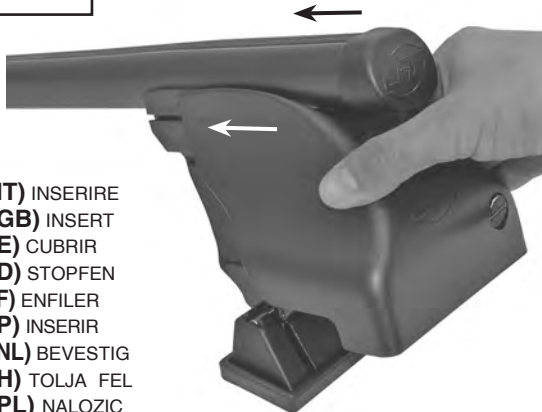

(IT) INSERIRE
(GB) INSERT
(E) CUBRIR
(D) STOPFEN
(F) ENFILER
(P) INSERIR
(NL) BEVESTIG
(H) TOLJA FEL
(PL) NALOZIC
(SLO) VSTAVITI
(HR) PREKRITI

3



4



(IT) INSERIRE
(GB) INSERT
(E) CUBRIR
(D) STOPFEN
(F) ENFILER
(P) INSERIR
(NL) BEVESTIG
(H) TOLJA FEL
(PL) NALOZIC
(SLO) VSTAVITI
(HR) PREKRITI



NO PER ART. 40102 - 40115 - 40119