

(IT) Attenzione: Istruzioni di montaggio per barre in alluminio.
(GB) Attention: Mounting instructions for aluminium bar carriers.
(E) Atención: Instrucciones de montaje para barras portatodo en aluminio.
(D) Achtung: Montageanweisungen für Aluminium-Lastenträger.
(F) Attention: Notices de montage pour barres de portage en aluminium.
(NL) Attentie: Handleiding voor dakdragers gemaakt van aluminium.
(P) Atenção: Instruções de montagem para barras de tejadilho en aluminio.
(H) Szerelési utasítás alumínium tartórudakhoz.
(PL) Uwaga: Instrukcja montażu bagażników wykonanych ze aluminium.
(SLO) Pozor: Navodila za montažo nosilcev prtljažnika - aluminijastih.
(HR) Uputstvo za montažu aluminijaskih nosača.

1

ZOOM

(A) **(IT)** SVITARE **(GB)** UNSCREW **(E)** AFLOJAR **(D)** ABSCHRAUBEN **(F)** DEVISSER **(NL)** OPENSCHROEVEN **(P)** DESAPARAFUSAR **(H)** KICSAVARNI **(PL)** WYKRECIC **(SLO)** ODVITI **(HR)** ODVITI

(B) **(IT)** INSERIRE **(GB)** INSERT **(E)** CUBRIR **(D)** STOPFEN **(F)** ENFILER **(NL)** BEVESTIG

(C) **(P)** INSERIR **(H)** TOLJA FEL **(PL)** NALOZIC **(SLO)** VSTAVITI **(HR)** PREKRITI

(D) **(IT)** AVVITARE **(GB)** TO SCREW **(E)** APRETAR **(D)** FESTSCHRAUBEN **(F)** VISSER **(NL)** VASTSCHROEVEN

(P) APERTAR **(H)** MEGHÚZNI **(PL)** WKRECIC **(SLO)** PRIVITI **(HR)** PRIČVRSTITI

2

ZOOM

(IT) INSERIRE **(GB)** INSERT **(E)** CUBRIR **(D)** STOPFEN **(F)** ENFILER **(NL)** BEVESTIG

(P) INSERIR **(H)** TOLJA FEL **(PL)** NALOZIC **(SLO)** VSTAVITI **(HR)** PREKRITI

3

(IT) MODELLI AUTO (GB) CARS (E) COCHES (D) WAGEN (F) VOITURES	(NL) AUTO (P) MODELO AUTO (H) AUTÓ TÍPUS (PL) MODELE SAMOCHODÓW (SLO) MODELI AVTOMOBILOV (HR) MODELI AUTA	(IT) ANTERIORE (GB) FRONT (E) DELANTERO (D) VORDERE (F) AVANT	(NL) VOORSTEG. (P) À FRENTE (H) ELSŐ RÜD (PL) PRZOD (SLO) SPREDAJ (HR) PREDNJI	(IT) POST. (GB) REAR (E) TRASERO (D) HINTERE (F) ARRIERE	(NL) ACHTERSTE G. (P) ATRÁS (H) HÁTSÓ RÜD (PL) TYŁ (SLO) ZADAJ (HR) STRAŽNJI
CITROEN XSARA 5P	100 mm	112 mm			
NISSAN ALMERA 5P (->99)	96 mm	96 mm			
NISSAN ALMERA 5P (00->)	109 mm	114 mm			
NISSAN ALMERA TINO 5P (99->)	44 mm	54 mm			
NISSAN PRIMERA (90->96)	80 mm	92 mm			
NISSAN PRIMERA 5P (97->01)	77 mm	90 mm			
RENAULT CLIO II 5P (98->12)	118 mm	118 mm			
RENAULT CLIO STORIA 5P	118 mm	118 mm			
RENAULT LAGUNA II (01->07)	67 mm	78 mm			
RENAULT R 21	80 mm	85 mm			
RENAULT SAFRANE	67 mm	67 mm			

(IT) MISURE PRECISE **(GB)** EXACT DIMENSIONS **(E)** MEDIDAS CORRECTAS **(D)** GENAUE MASSE **(F)** MESURES EXACTES **(NL)** EXACTE AFMETINGEN **(P)** MEDIDAS PRECISAS **(H)** PONTOS MÉRET **(PL)** DOKŁADNE WYMIARY **(SLO)** TOČNE MERE **(HR)** PRECIZNE MJERE

ZOOM

(IT) TAGLIARE **(GB)** TO CUT **(E)** CORTAR **(D)** SCHNEIDEN **(F)** COUPER **(NL)** SNIJDEN **(P)** CORTAR **(H)** ELVÁGNI **(PL)** OBCIAC **(SLO)** ODREZATI **(HR)** ODREZATI

4

(IT) AVVITARE (A FONDO)
(GB) TO SCREW (DOWN)
(E) APRETAR (A FONDO)
(D) FESTSCHRAUBEN
(F) VISSER (À FOND)
(NL) VASTSCHROEVEN
(P) APERTAR POR BAIXO
(H) MEGHÚZNI
(PL) WKRECIC DO KONCA
(SLO) PRIVITI (DO KONCA)
(HR) PRIČVRSTITI (DO KRAJA)

10 Nm

5

(IT) INSERIRE **(GB)** INSERT **(E)** CUBRIR **(D)** STOPFEN **(F)** ENFILER **(NL)** BEVESTIG **(H)** TOLJA FEL **(PL)** NALOZIC **(SLO)** VSTAVITI **(HR)** PREKRITI

6

(IT) TAGLIARE **(GB)** TO CUT **(E)** CORTAR **(D)** SCHNEIDEN **(F)** COUPER **(NL)** SNIJDEN **(P)** CORTAR **(H)** ELVÁGNI **(PL)** OBCIAC **(SLO)** ODREZATI **(HR)** ODREZATI

(IT) INSERIRE **(GB)** INSERT **(E)** CUBRIR **(D)** STOPFEN **(F)** ENFILER **(NL)** BEVESTIG **(H)** TOLJA FEL **(PL)** NALOZIC **(SLO)** VSTAVITI **(HR)** PREKRITI

7

(IT) INSERIRE **(GB)** INSERT **(E)** CUBRIR **(D)** STOPFEN **(F)** ENFILER **(NL)** BEVESTIG

(P) INSERIR **(H)** TOLJA FEL **(PL)** NALOZIC **(SLO)** VSTAVITI **(HR)** PREKRITI

(IT) TAGLIARE **(GB)** TO CUT **(E)** CORTAR **(D)** SCHNEIDEN **(F)** COUPER **(NL)** SNIJDEN **(P)** CORTAR **(H)** ELVÁGNI **(PL)** OBCIAC **(SLO)** ODREZATI **(HR)** ODREZATI

8 **18**

(IT) MONTAGGIO GANASCINE
(GB) HOW TO ASSEMBLE THE CLAMPS
(E) COMO MONTAR LAS FIJACIONES
(D) ZUSAMMENBAU DER SPANNBACKEN
(F) MONTAGE PATTE
(NL) MONTAGE VAN DE KLEMMEN
(P) COMO FIXAR OS SUPORTES
(H) RÖGZITŐ FÜLEK
(PL) MONTAZ SZCZEK MOCUJACYCH
(SLO) MONTAŽA NAPENJALNIKA
(HR) MONTAŽA ČELJUSTI

9

(IT) PULIRE IL TETTO
(GB) CLEAN THE ROOF
(E) LIMPIAR EL TECHO
(D) DACH REINIGEN
(F) NETTOYER LE TOIT
(NL) DAK SCHOONMAKEN
(P) LIMPAR O TEJADILHO
(H) TISZTÍTSA MEG A TETŐT
(PL) WYCZYSCIC DACH
(SLO) OČISTITI STREHO
(HR) ČIŠTENJE KROVA

10

OPTIMUM
700 mm

11

OK
NO

(IT) CENTRARE IL P. TUTTO SUL TETTO
(GB) CENTRE THE UNIVERSAL BAR CARRIER ON THE ROOF
(E) CENTRAR EL PORTAEQUIPAJES SOBRE EL TECHO
(D) LASTENTRÄGER AUF DEM DACH ZENTRIEREN
(F) CENTRER LE PORTE-TOUT SUR LE TOIT
(NL) PLAATS DE UNIVERSELE DRAGER IN HET MIDDEN VAN HET DAK
(P) CENTRAR AS BARRAS PORTA BAGAGENS NO TEJADILHO
(H) HELYEZZE KÖZÉPRE A RUDAKAT
(PL) WYSRODKOWAC BAGAŻNIK NA DACHU
(SLO) CENTRIRATI PRTLJAŽNIK NA STREHO
(HR) CENTRIRATI NOSAČE NA KROV

(IT) MODELLI SENZA PREDISPOSIZIONE DELLA CASA AUTO
(GB) CARS WITHOUT PRE-EXISTING FIXING POINT
(E) PARA COCHES SIN PREDISPOSICION DEL FABRICANTE
(D) AUTOS OHNE VOM HERSTELLER VORGESEHENE BEFESTIGUNGSPUNKTE
(F) VOITURES SANS POINTS DE RÉPÈRE PRÉVUS PAR LE CONSTRUCTEUR
(NL) AUTO'S ZONDER DOOR DE FABRIKANT VOORZIENE BEVESTIGINGSPUNTEN
(P) VIATURAS SEM PONTOS DE FIXAÇÃO DO CONSTRUTOR PRÉ-EXISTENTES
(H) FELHELYEZÉS GYÁRI JELŐLÉS NÉLKÜLI AUTÓKRA
(PL) SAMOCHODY BEZ PRZEWIDZIANYCH PUNKTOW UMOCOWANIA
(SLO) MODELI Z NEPREDVIDENIM LEŽIŠČEM S STRANI PROIZVAJALCA
(HR) TVORNIČKI NEPRIPREMLJENI MODELI

12

T mm
Z mm

(IT) MODELLI AUTO (GB) CARS (E) COCHES (D) WAGEN (F) VOITURES (NL) AUTO (P) MODELO AUTO (H) AUTÓ TIPUS (PL) MODELE SAMOCHODÓW (SLO) MODELI AVTOMOBILOV (HR) MODELI AUTA	(IT) ANTERIORE (GB) FRONT (E) DELANTERO (D) VORDERE (F) AVANT (NL) VOORSTE G. (P) À FRENTE (H) ELSŐ RÚD (PL) PRZOD (SLO) SPREDAJ (HR) PREDNJI	(IT) POSTERIORE (GB) REAR (E) TRASERO (D) HINTERE (F) ARRIERE (NL) ACHTERSTE G. (P) ATRÁS (H) HÁTSÓ RÚD (PL) TYL (SLO) ZADAJ (HR) STRAŽNJI
NISSAN ALMERA 5P (->99)	T (270 mm)	Z (330 mm)
NISSAN ALMERA 5P (00->)	T (250 mm)	Z (400 mm)
NISSAN ALMERA TINO 5P (99->)	T (230 mm)	Z (400 mm)
NISSAN PRIMERA (90->96)	T (350 mm)	Z (350 mm)
NISSAN PRIMERA 5P (97->01)	T (400 mm)	Z (260 mm)
RENAULT R21	T (350 mm)	Z (350 mm)
RENAULT SAFRANE	T (350 mm)	Z (350 mm)

(IT) AVVITARE
(GB) TO SCREW
(E) APRETAR
(D) FESTSCHRAUBEN
(F) VISSER
(NL) VASTSCHROEVEN
(P) APERTAR
(H) MEGHÚZNI
(PL) WKRECIC
(SLO) PRIVITI
(HR) PRIČVRSTITI

5 Nm

(IT) MODELLI CON PREDISPOSIZIONE DELLA CASA AUTO
(GB) CARS WITH PRE-EXISTING FIXING POINT FROM MANUFACTURER
(E) MODELOS CON PREDISPOSICION DEL FABRICANTE
(D) AUTOS MIT VOM HERSTELLER VORGESEHENE BEFESTIGUNGSPUNKTE
(F) VOITURES AVEC POINTS DE RÉPÈRE PRÉVUS PAR LE CONSTRUCTEUR
(NL) AUTO'S MET DOOR DE FABRIKANT VOORZIENE MONTAGEPUNTEN
(P) VIATURAS COM PONTOS DE FIXAÇÃO DO CONSTRUTOR PRÉ-EXISTENTES
(H) FELHELYEZÉS GYÁRTÓ ÁLTAL KIJELÖLT PONTRA
(PL) SAMOCHODY Z PRZEWIDZIANYMI PUNKTAMI UMOCOWANIA
(SLO) MODELI Z PREDVIDENIM LEŽIŠČEM S STRANI PROIZVAJALCA
(HR) TVORNIČKI PRIPREMLJENI MODELI

"À TROUVER SUR LE BATTANT DE LA PORTE OU DANS LE MANUAL TECHNIQUE DE LA VOITURE "

13

(IT) MODELLI AUTO (GB) CARS (E) COCHES (D) WAGEN (F) VOITURES (NL) AUTO (P) MODELO AUTO (H) AUTÓ TIPUS (PL) MODELE SAMOCHODÓW (SLO) MODELI AVTOMOBILOV (HR) MODELI AUTA	(IT) ANTERIORE (GB) FRONT (E) DELANTERO (D) VORDERE (F) AVANT (NL) VOORSTE G. (P) À FRENTE (H) ELSŐ RÚD (PL) PRZOD (SLO) SPREDAJ (HR) PREDNJI	(IT) POSTERIORE (GB) REAR (E) TRASERO (D) HINTERE (F) ARRIERE (NL) ACHTERSTE G. (P) ATRÁS (H) HÁTSÓ RÚD (PL) TYL (SLO) ZADAJ (HR) STRAŽNJI
CITROEN XSARA 5P	T	Z
RENAULT CLIO II 5P (98->12)	T	Z
RENAULT CLIO STORIA 5P	T	Z
RENAULT LAGUNA II (01->07)	T	Z

(IT) AVVITARE
(GB) TO SCREW
(E) APRETAR
(D) FESTSCHRAUBEN
(F) VISSER
(NL) VASTSCHROEVEN
(P) APERTAR
(H) MEGHÚZNI
(PL) WKRECIC
(SLO) PRIVITI
(HR) PRIČVRSTITI

5 Nm



(IT) **Attenzione:** Istruzioni di montaggio per barre in ferro.
 (GB) **Attention:** Mounting instructions for steel bar carriers.
 (E) **Atencion:** Instrucciones de montaje para barras portatodo en hierro.
 (D) **Achtung:** Montageanweisungen für Stahl-Lastenträger.
 (F) **Attention:** Notices de montage pour barres de portage en métal.
 (NL) **Attentie:** Handleiding voor dakdragers gemaakt van ijzer.
 (P) **Atenção:** Instrukções de montagem para barras de tejadilho em ferro.
 (H) **Szerelési utasítás** acél tartórudakhoz.
 (PL) **Uwaga:** Instrukcja montażu bagażników wykonanych ze stali.
 (SLO) **Pozor:** Navodila za montažo nosilcev prtljažnika-železnih.
 (HR) **Uputstvo za** montažu željeznih krovnih nosača.

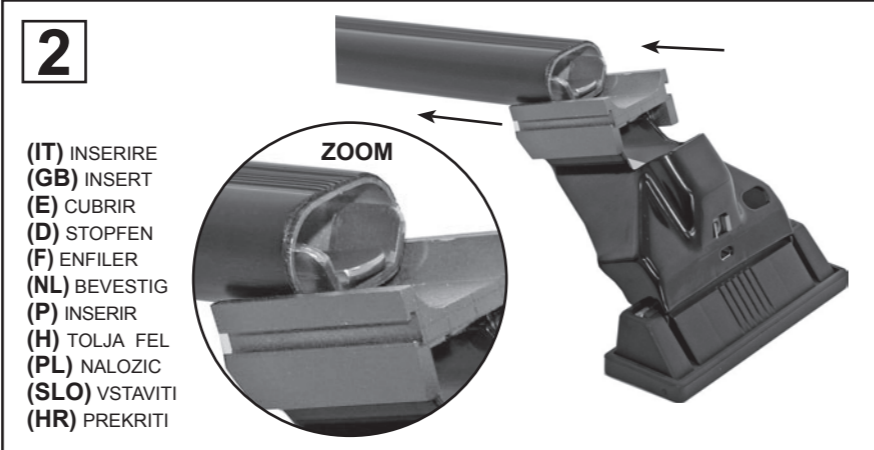
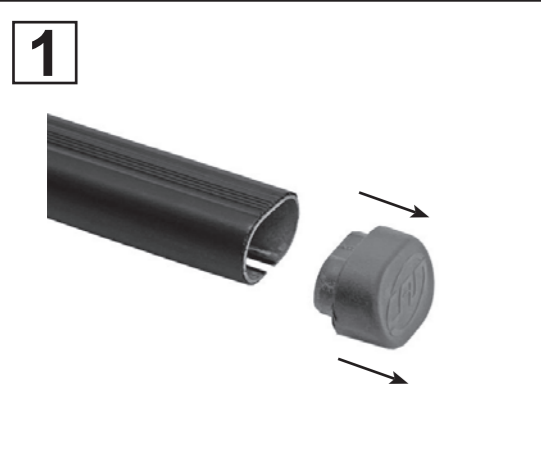

(IT) INSERIRE
 (GB) INSERT
 (E) CUBRIR
 (D) STOPFEN
 (F) ENFILER
 (NL) BEVESTIG
 (P) INSERIR
 (H) TOLJA FEL
 (PL) NALOZIC
 (SLO) VSTAVITI
 (HR) PREKRITI

(IT) MODELLI AUTO (GB) CARS (E) COCHES (D) WAGEN (F) VOITURES	(NL) AUTO (P) MODELO AUTO (H) AUTO TIPUS (PL) MODELE SAMOCHODÓW (SLO) MODELI AVTOMOBILOV (HR) MODELI AUTA	(IT) ANTERIORE (GB) FRONT (E) DELANTERO (D) VORDERE (F) AVANT	(NL) VOORSTE G. (P) À FRENTE (H) ELSÓ RÚD (PL) PRZOD (SLO) SPREDAJ (HR) PREDNJI	(IT) POST. (GB) REAR (E) TRASERO (D) HINTERE (F) ARRIERE	(NL) ACHTERSTE G. (P) ATRÁS (H) HÁTSÓ RÚD (PL) TYŁ (SLO) ZÁDAJ (HR) STRAŽNJI
CITROEN XSARA 5P		100 mm		112 mm	
NISSAN ALMERA 5P (->99)		96 mm		96 mm	
NISSAN ALMERA 5P (00->)		109 mm		114 mm	
NISSAN ALMERA TINO 5P (99->)		44 mm		54 mm	
NISSAN PRIMERA (90->96)		80 mm		92 mm	
NISSAN PRIMERA 5P (97->01)		77 mm		90 mm	
RENAULT CLIO II 5P (98->12)		118 mm		118 mm	
RENAULT CLIO STORIA 5P		118 mm		118 mm	
RENAULT LAGUNA II (01->07)		67 mm		78 mm	
RENAULT R 21		80 mm		85 mm	
RENAULT SAFRANE		67 mm		67 mm	

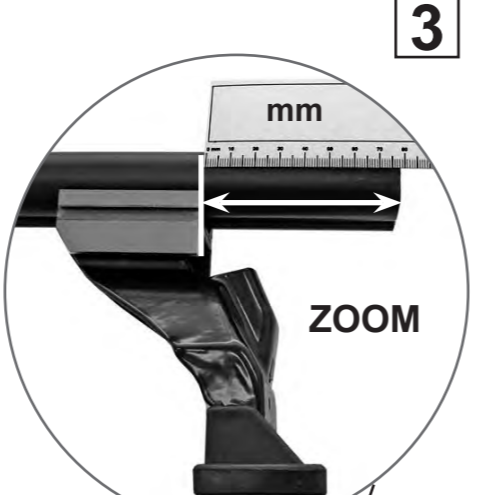

3



(IT) MISURE PRECISE
 (GB) EXACT DIMENSIONS
 (E) MEDIDAS CORRECTAS
 (D) GENAUE MASSE
 (F) MESURES EXACTES
 (NL) EXACTE AFMETINGEN
 (P) MEDIDAS PRECISAS
 (H) PONTOS MÉRET
 (PL) DOKŁADNE WYMIARY
 (SLO) TOČNE MERE
 (HR) PRECIZNE MJERE

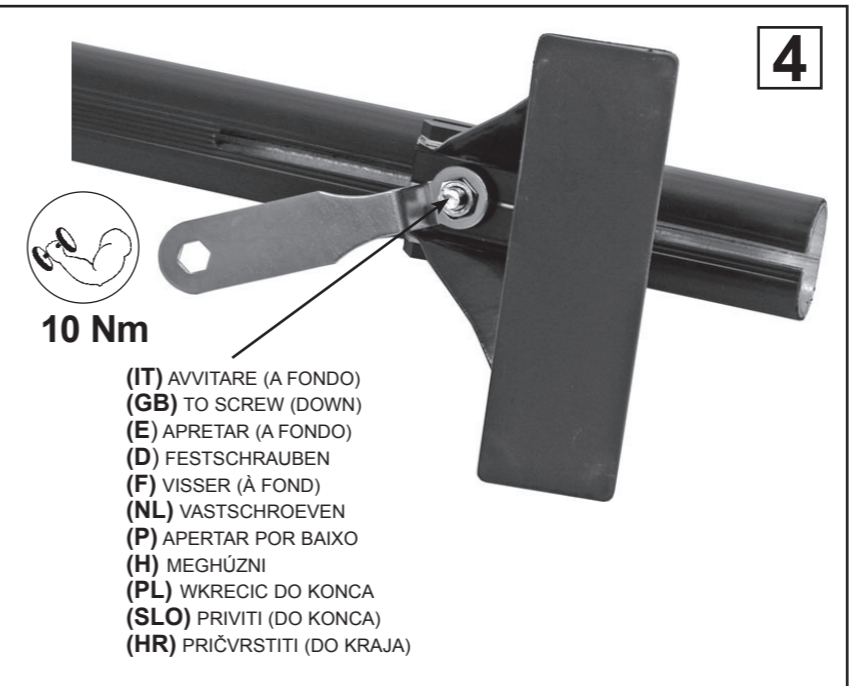

10 Nm
 (IT) AVVITARE (A FONDO)
 (GB) TO SCREW (DOWN)
 (E) APRETAR (A FONDO)
 (D) FESTSCHRAUBEN
 (F) VISSER (À FOND)
 (NL) VASTSCHROEVEN
 (P) APERTAR POR BAIXO
 (H) MEGHÚZNI
 (PL) WKRECIC DO KONCA
 (SLO) PRIVITI (DO KONCA)
 (HR) PRIČVRSTITI (DO KRAJA)

4

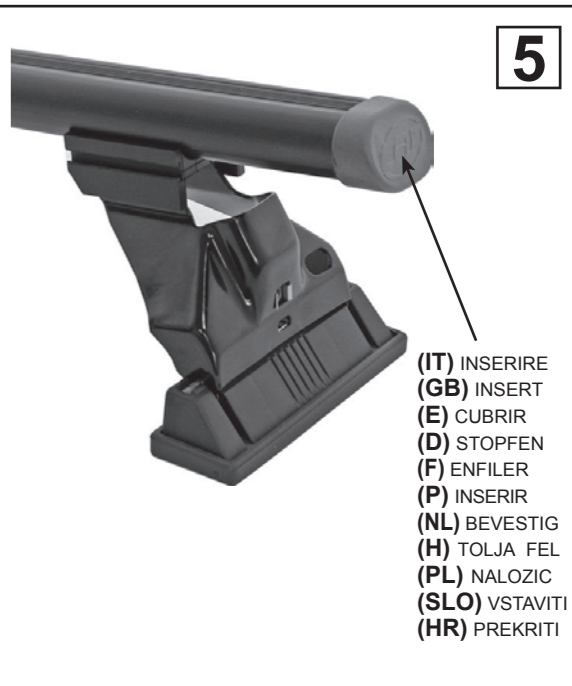

(IT) INSERIRE
 (GB) INSERT
 (E) CUBRIR
 (D) STOPFEN
 (F) ENFILER
 (P) INSERIR
 (NL) BEVESTIG
 (H) TOLJA FEL
 (PL) NALOZIC
 (SLO) VSTAVITI
 (HR) PREKRITI

5

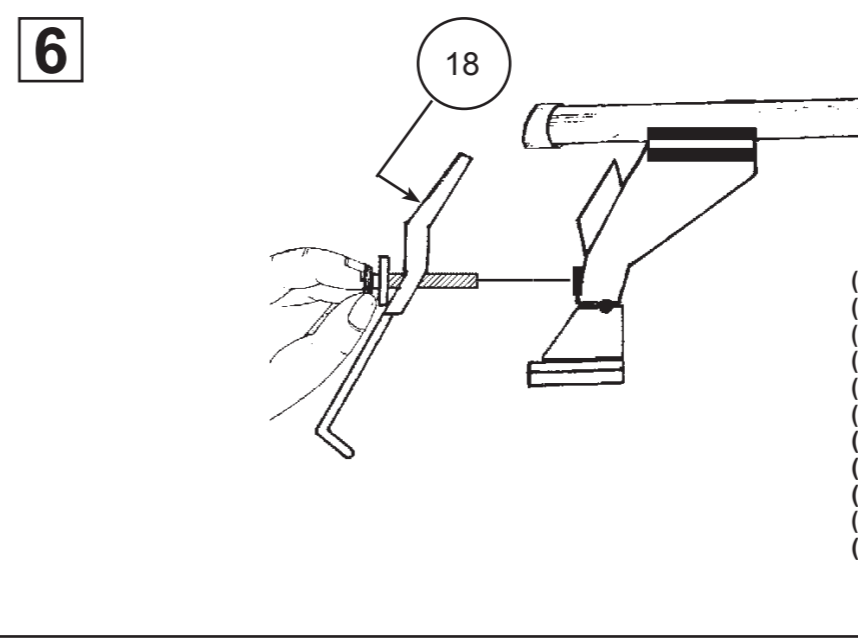

(IT) MONTAGGIO GANASCINE
 (GB) HOW TO ASSEMBLE THE CLAMPS
 (E) COMO MONTAR LAS FIJACIONES
 (D) ZUSAMMENBAU DER SPANNBACKEN
 (F) MONTAGE PATTE
 (NL) MONTAGE VAN DE KLEMMEN
 (P) COMO FIXAR OS SUPORTES
 (H) RÖGZITŐ FÜLEK
 (PL) MONTAZ SZCZEK MOCUJACYCH
 (SLO) MONTAŽA NAPENJALNIKA
 (HR) MONTAŽA ČELJUSTI

6

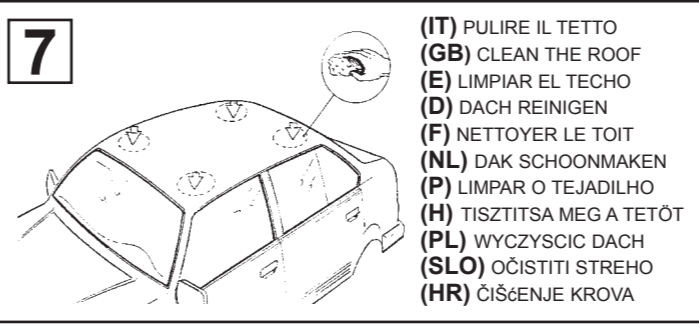

(IT) PULIRE IL TETTO
 (GB) CLEAN THE ROOF
 (E) LIMPIAR EL TECHO
 (D) DACH REINIGEN
 (F) NETTOYER LE TOIT
 (NL) DAK SCHOONMAKEN
 (P) LIMPAR O TEJADILHO
 (H) TISZTÍTSA MEG A TETŐT
 (PL) WYCZYŚCIC DACH
 (SLO) OČISTITI STREHO
 (HR) ČIŠĆENJE KROVA

7

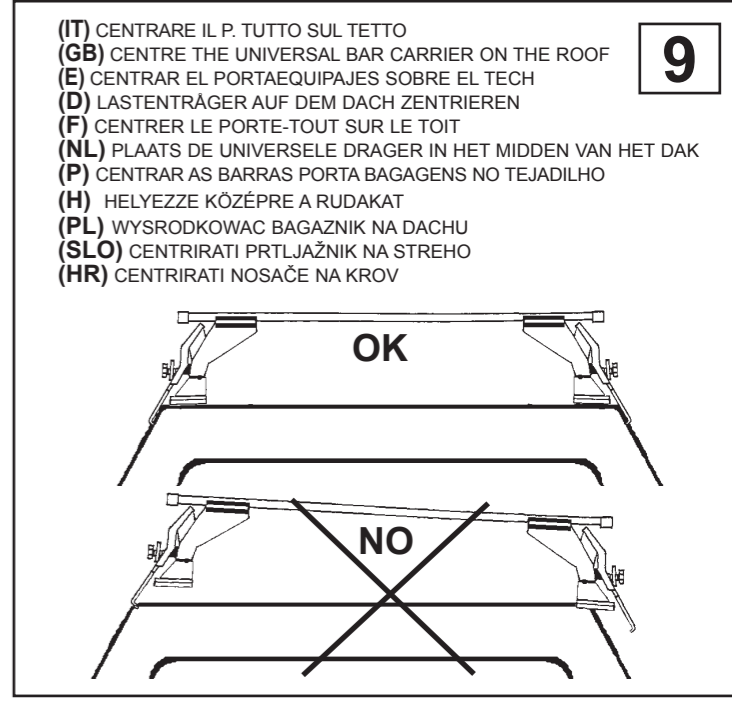

(IT) CENTRARE IL P. TUTTO SUL TETTO
 (GB) CENTRE THE UNIVERSAL BAR CARRIER ON THE ROOF
 (E) CENTRAR EL PORTAEQUIPAJES SOBRE EL TECH
 (D) LASTENTRÄGER AUF DEM DACH ZENTRIEREN
 (F) CENTRER LE PORTE-TOUT SUR LE TOIT
 (NL) PLAATS DE UNIVERSELE DRAGER IN HET MIDDEN VAN HET DAK
 (P) CENTRAR AS BARRAS PORTA BAGAGENS NO TEJADILHO
 (H) HELYEZZE KÖZÉPRE A RUDAKAT
 (PL) WYSRODKOWAC BAGAŻNIK NA DACHU
 (SLO) CENTRIRATI PRTLJAŽNIK NA STREHO
 (HR) CENTRIRATI NOSAČE NA KROV

9

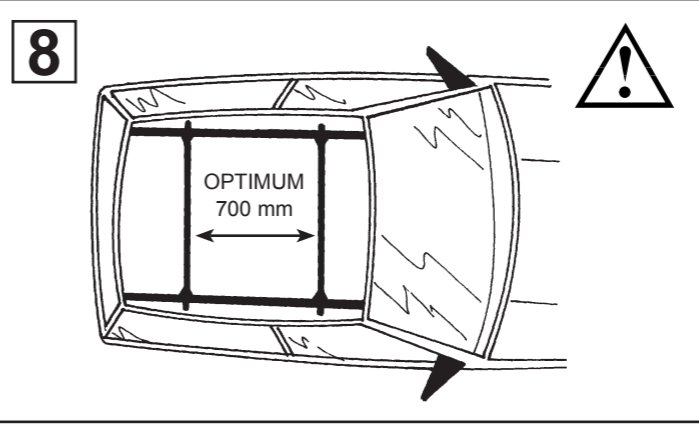

8



(IT) MODELLI CON PREDISPOSIZIONE DELLA CASA AUTO
 (GB) CARS WITH PRE-EXISTING FIXING POINT FROM MANUFACTURER
 (E) MODELOS CON PREDISPOSICION DEL FABRICANTE
 (D) AUTOS MIT VOM HERSTELLER VORGESEHENE BEFESTIGUNGSPUNKTE
 (F) VOITURES AVEC POINTS DE RÉPÈRE PREVUS PAR LE CONSTRUCTEUR
 (NL) AUTO'S MET DOOR DE FABRIKANT VOORZIENE MONTAGEPUNTEN
 (P) VIATURAS COM PONTOS DE FIXAÇÃO DO CONSTRUTOR PRÉ-EXISTENTES
 (H) FELHÉLYEZÉS GYÁRTÓ ÁLTAL KIJELÖLT PONTRA
 (PL) SAMOCHODY Z PRZEWIDZIANYMI PUNKTAMI UMOCOWANIA
 (SLO) MODELI Z PREDVIDENIM LEŽIŠČEM S STRANI PROIZVAJALCA
 (HR) TVORNIČKI PRIPREMLJENI MODELI

“À TROUVER SUR LE BATTANT DE LA PORTE OU
 DANS LE MANUAL TECHNIQUE DE LA VOITURE “

10

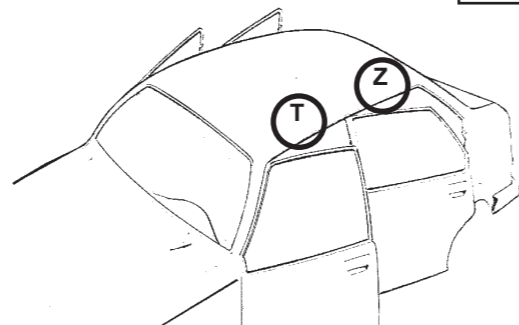

(IT) MODELLI AUTO (GB) CARS (E) COCHES (D) WAGEN (F) VOITURES (NL) AUTO (P) MODELO AUTO (H) AUTÓ TIPUS (PL) MODELE SAMOCHODÓW (SLO) MODELI AVTOMOBILOV (HR) MODELI AUTA	(IT) ANTERIORE (GB) FRONT (E) DELANTERO (D) VORDERE (F) AVANT (NL) VOORSTE G. (P) À FRENTE (H) ELSŐ RÚD (PL) PRZOD (SLO) SPREDAJ (HR) PREDNJI	(IT) POSTERIORE (GB) REAR (E) TRASERO (D) HINTERE (F) ARRIERE (NL) ACHTERSTE G. (P) ATRÁS (H) HÁTSÓ RÚD (PL) TYŁ (SLO) ZADAJ (HR) STRAŽNJI
CITROEN XSARA 5P	T	Z
RENAULT CLIO II 5P (98->12)	T	Z
RENAULT CLIO STORIA 5P	T	Z
RENAULT LAGUNA II (01->07)	T	Z

(IT) AVVITARE
 (GB) TO SCREW
 (E) APRETAR
 (D) FESTSCHRAUBEN
 (F) VISSER
 (NL) VASTSCHROEVEN
 (P) APERTAR
 (H) MEGHÚZNI
 (PL) WKRECIC
 (SLO) PRIVITI
 (HR) PRIČVRSTITI

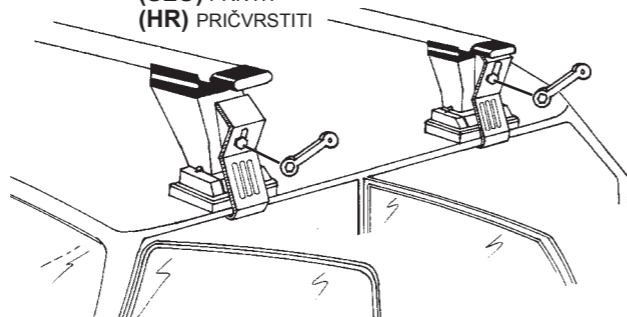

(IT) MODELLI SENZA PREDISPOSIZIONE DELLA CASA AUTO
 (GB) CARS WITHOUT PRE-EXISTING FIXING POINT
 (E) PARA COCHES SIN PREDISPOSICION DEL FABRICANTE
 (D) AUTOS OHNE VOM HERSTELLER VORGESEHENE BEFESTIGUNGSPUNKTE
 (F) VOITURES SANS POINTS DE RÉPÈRE PRÉVUS PAR LE CONSTRUCTEUR
 (NL) AUTO'S ZONDER DOOR DE FABRIKANT VOORZIENE BEVESTIGINGSPUNTEN
 (P) VIATURAS SEM PONTOS DE FIXAÇÃO DO CONSTRUTOR PRÉ-EXISTENTES
 (H) FELHÉLYEZÉS GYÁRI JELÖLÉS NÉLKÜLI AUTÓKRA
 (PL) SAMOCHODY BEZ PRZEWIDZIANYCH PUNKTOW UMOCOWANIA
 (SLO) MODELI Z NEPREDVIDENIM LEŽIŠČEM S STRANI PROIZVAJALCA
 (HR) TVORNIČKI NEPRIPREMLJENI MODELI



T mm Z mm

11

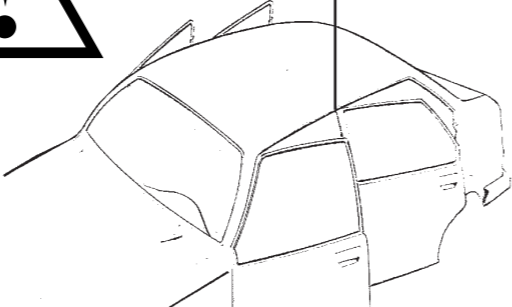

(IT) MODELLI AUTO (GB) CARS (E) COCHES (D) WAGEN (F) VOITURES (NL) AUTO (P) MODELO AUTO (H) AUTÓ TIPUS (PL) MODELE SAMOCHODÓW (SLO) MODELI AVTOMOBILOV (HR) MODELI AUTA	(IT) ANTERIORE (GB) FRONT (E) DELANTERO (D) VORDERE (F) AVANT (NL) VOORSTE G. (P) À FRENTE (H) ELSŐ RÚD (PL) PRZOD (SLO) SPREDAJ (HR) PREDNJI	(IT) POSTERIORE (GB) REAR (E) TRASERO (D) HINTERE (F) ARRIERE (NL) ACHTERSTE G. (P) ATRÁS (H) HÁTSÓ RÚD (PL) TYŁ (SLO) ZADAJ (HR) STRAŽNJI
NISSAN ALMERA 5P (->99)	T (270 mm)	Z (330 mm)
NISSAN ALMERA 5P (00->)	T (250 mm)	Z (400 mm)
NISSAN ALMERA TINO 5P (99->)	T (230 mm)	Z (400 mm)
NISSAN PRIMERA (90->96)	T (350 mm)	Z (350 mm)
NISSAN PRIMERA 5P (97->01)	T (400 mm)	Z (260 mm)
RENAULT R21	T (350 mm)	Z (350 mm)
RENAULT SAFRANE	T (350 mm)	Z (350 mm)

(IT) AVVITARE
 (GB) TO SCREW
 (E) APRETAR
 (D) FESTSCHRAUBEN
 (F) VISSER
 (NL) VASTSCHROEVEN
 (P) APERTAR
 (H) MEGHÚZNI
 (PL) WKRECIC
 (SLO) PRIVITI
 (HR) PRIČVRSTITI

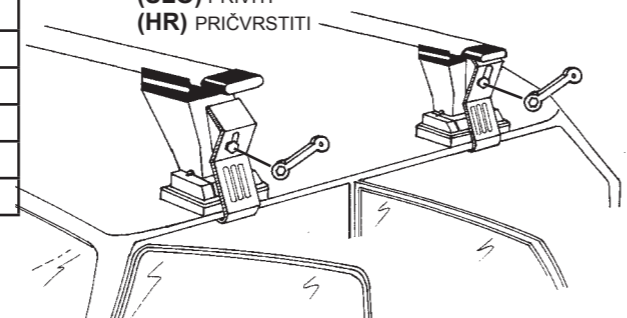

40018 PARTS LIST

x4 Cod. VTBS08P30



x4 Cod. 32052/Z



x4 Cod. ROZB08016



x4 Cod. DDFZ08001



x4 Cod. 60328

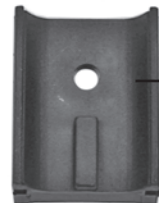

x4 Cod. 32053/Z

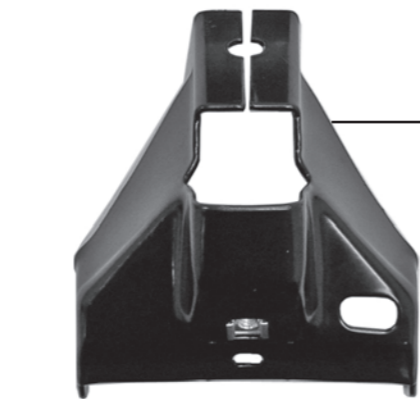
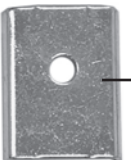

x4 Cod. 31051/V



x4 Cod. 57619



x4 Cod. DDFZ06006



x4 Cod. 60243

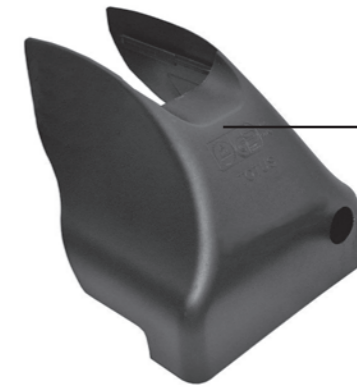

x4 Cod. 60239



x4 Cod. 60263



x1 Cod. 60273

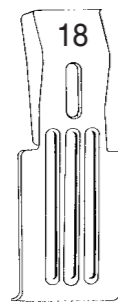

x4 Cod. 31756/V

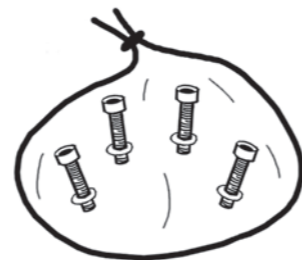

x1 Cod. 37930/M



mm

x1 Cod. 55099



x1 Cod. 32032/Z

COVER TOTUS

(IT) ISTRUZIONI DI MONTAGGIO (GB) FITTING INSTRUCTIONS (E) INSTRUCCIONES PARA SU MONTAJE
(D) MONTAGEANWEISUNGEN (F) INSTRUCTIONS DE MONTAGE (NL) MONTAGE INSTRUCTIES (P) INSTRUÇÕES DE MONTAGEM
(H) SZERELÉSI UTASÍTÁS (PL) INSTRUKCJA MONTAŻU (SLO) NAVODILA O MONTAŽI (HR) UPUTE ZA MONTAŽU.

1



(IT) INSERIRE
(GB) INSERT
(E) CUBRIR
(D) STOPFEN
(F) ENFILER
(P) INSERIR
(NL) BEVESTIG
(H) TOLJA FEL
(PL) NALOZIC
(SLO) VSTAVITI
(HR) PREKRITI



2

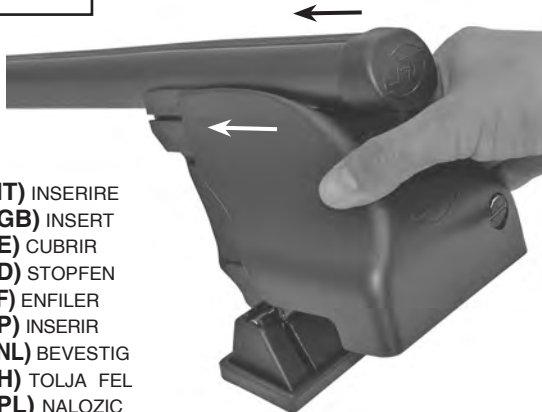

(IT) INSERIRE
(GB) INSERT
(E) CUBRIR
(D) STOPFEN
(F) ENFILER
(P) INSERIR
(NL) BEVESTIG
(H) TOLJA FEL
(PL) NALOZIC
(SLO) VSTAVITI
(HR) PREKRITI

3



4



(IT) INSERIRE
(GB) INSERT
(E) CUBRIR
(D) STOPFEN
(F) ENFILER
(P) INSERIR
(NL) BEVESTIG
(H) TOLJA FEL
(PL) NALOZIC
(SLO) VSTAVITI
(HR) PREKRITI



NO PER ART. 40102 - 40115 - 40119