

(IT) Attenzione: Istruzioni di montaggio per barre in alluminio.
(GB) Attention: Mounting instructions for aluminium bar carriers.
(E) Atención: Instrucciones de montaje para barras portatodo en aluminio.
(D) Achtung: Montageanweisungen für Aluminium-Lastenträger.
(F) Attention: Notices de montage pour barres de portage en aluminium.
(NL) Attentie: Handleiding voor dakdragers gemaakt van aluminium.
(P) Atenção: Instruções de montagem para barras de tejadilho em alumínio.
(H) Szerelési utasítás aluminium tartórudakhoz.
(PL) Uwaga: Instrukcja montażu bagażników wykonanych ze aluminium.
(SLO) Pozor: Navodila za montažo nosilcev prtljažnika - aluminijastih.
(HR) Uputstvo za montažu aluminijaskih nosača.

1

ZOOM

(A)

(B)

(C)

(D)

(IT) SVITARE
(GB) UNSCREW
(E) AFLOJAR
(D) ABSCHRAUBEN
(F) DEVISSER
(NL) OPENSCHROEVEN
(P) DESAPARAFUSAR
(H) KICSAVARNI
(PL) WYKRECIC
(SLO) ODVITI
(HR) ODVITI

(IT) INSERIRE
(GB) INSERT
(E) CUBRIR
(D) STOPFEN
(F) ENFILER
(NL) BEVESTIG

(P) INSERIR
(H) TOLJA FEL
(PL) NALOZIC
(SLO) VSTAVITI
(HR) PREKRITI

(IT) AVVITARE
(GB) TO SCREW
(E) APRETAR
(D) FESTSCHRAUBEN
(F) VISSER
(NL) VASTSCHROEVEN

(P) APERTAR
(H) MEGHÚZNI
(PL) WKRECIC
(SLO) PRIVITI
(HR) PRIČVRSTITI

2

ZOOM

(IT) INSERIRE
(GB) INSERT
(E) CUBRIR
(D) STOPFEN
(F) ENFILER
(NL) BEVESTIG

(P) INSERIR
(H) TOLJA FEL
(PL) NALOZIC
(SLO) VSTAVITI
(HR) PREKRITI

3

<p>(IT) MODELLI AUTO (GB) CARS (E) COCHES (D) WAGEN (F) VOITURES</p>	<p>(NL) AUTO (P) MODELO AUTO (H) AUTÓ TIPUS (PL) MODELE SAMOCHODÓW (SLO) MODELI AVTOMOBILOV (HR) MODELI AUTA</p>	<p>(IT) ANTERIORE (GB) FRONT (E) DELANTERO (D) VORDERE (F) AVANT</p>	<p>(NL) VOORSTE G. (P) À FRENTE (H) ELSŐ RÚD (PL) PRZOD (SLO) SPREDAJ (HR) PREDNJI</p>	<p>(IT) POST. (GB) REAR (E) TRASERO (D) HINTERE (F) ARRIERE</p>	<p>(NL) ACHTERSTE G. (P) ATRÁS (H) HÁTSÓ RÚD (PL) TYŁ (SLO) ZADAJ (HR) STRAŽNJI</p>
<p>AUDI A3 3P (03->12)</p>		<p>118 mm</p>		<p>144 mm</p>	

ZOOM

(IT) MISURE PRECISE
(GB) EXACT DIMENSIONS
(E) MEDIDAS CORRECTAS
(D) GENAUE MASSE
(F) MESURES EXACTES
(NL) EXACTE AFMETINGEN
(P) MEDIDAS PRECISAS
(H) PONTOS MÉRET
(PL) DOKŁADNE WYMIARY
(SLO) TOČNE MERE
(HR) PRECIZNE MJERE

ZOOM

4

(IT) AVVITARE (A FONDO)
(GB) TO SCREW (DOWN)
(E) APRETAR (A FONDO)
(D) FESTSCHRAUBEN
(F) VISSER (À FOND)
(NL) VASTSCHROEVEN
(P) APERTAR POR BAIXO
(H) MEGHÚZNI
(PL) WKRECIC DO KONCA
(SLO) PRIVITI (DO KONCA)
(HR) PRIČVRSTITI (DO KRAJA)

10 Nm

5

(IT) INSERIRE
(GB) INSERT
(E) CUBRIR
(D) STOPFEN
(F) ENFILER
(P) INSERIR
(NL) BEVESTIG
(H) TOLJA FEL
(PL) NALOZIC
(SLO) VSTAVITI
(HR) PREKRITI

6

(IT) TAGLIARE
(GB) TO CUT
(E) CORTAR
(D) SCHNEIDEN
(F) COUPER
(NL) SNIJDEN
(P) CORTAR
(H) ELVÁGNI
(PL) OBCIAC
(SLO) ODREZATI
(HR) ODREZATI

(IT) INSERIRE
(GB) INSERT
(E) CUBRIR
(D) STOPFEN
(F) ENFILER
(NL) BEVESTIG

(P) INSERIR
(H) TOLJA FEL
(PL) NALOZIC
(SLO) VSTAVITI
(HR) PREKRITI

7

(IT) INSERIRE
(GB) INSERT
(E) CUBRIR
(D) STOPFEN
(F) ENFILER
(NL) BEVESTIG

(P) INSERIR
(H) TOLJA FEL
(PL) NALOZIC
(SLO) VSTAVITI
(HR) PREKRITI

(IT) TAGLIARE
(GB) TO CUT
(E) CORTAR
(D) SCHNEIDEN
(F) COUPER
(NL) SNIJDEN
(P) CORTAR
(H) ELVÁGNI
(PL) OBCIAC
(SLO) ODREZATI
(HR) ODREZATI

8

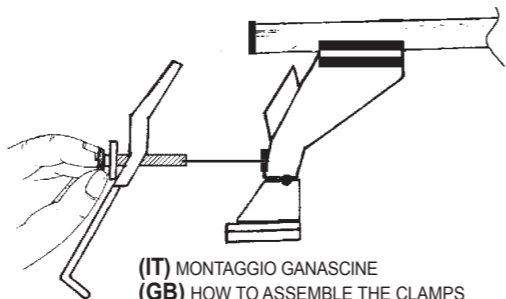
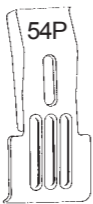
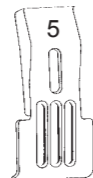

(IT) MONTAGGIO GANASCINE
(GB) HOW TO ASSEMBLE THE CLAMPS
(E) COMO MONTAR LAS FIJACIONES
(D) ZUSAMMENBAU DER SPANNBACKEN
(F) MONTAGE PATTE
(NL) MONTAGE VAN DE KLEMMEN
(P) COMO FIXAR OS SUPORTES
(H) RÖGZITŐ FÜLEK
(PL) MONTAZ SZCZEK MOCUJACYCH
(SLO) MONTAŽA NAPENJALNIKA
(HR) MONTAŽA ČELJUSTI

(IT) MODELLI AUTO (GB) CARS (E) COCHES (D) WAGEN (F) VOITURES (NL) AUTO (P) MODELO AUTO (H) AUTÓ TIPUS (PL) MODELE SAMOCHODÓW (SLO) MODELI AVTOMOBILOV (HR) MODELI AUTA	(IT) ANTERIORE (GB) FRONT (E) DELANTERO (D) VORDERE (F) AVANT (NL) VOORSTE G. (P) À FRENTE (H) ELSŐ RÚD (PL) PRZOD (SLO) SPREDAJ (HR) PREDNJI	(IT) POSTERIORE (GB) REAR (E) TRASERO (D) HINTERE (F) ARRIERE (NL) ACHTERSTE G. (P) ATRÁS (H) HÁTSÓ RÚD (PL) TYL (SLO) ZADAJ (HR) STRAŽNJI
AUDI A3 3P (03->12)	5	54P

9

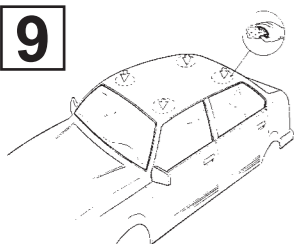

(IT) PULIRE IL TETTO
(GB) CLEAN THE ROOF
(E) LIMPIAR EL TECHO
(D) DACH REINIGEN
(F) NETTOYER LE TOIT
(NL) DAK SCHOONMAKEN
(P) LIMPAR O TEJADILHO
(H) TISZTÍTSÁ MEG A TETŐT
(PL) WYCZYSCIC DACH
(SLO) OČISTITI STREHO
(HR) ČIŠĆENJE KROVA



10

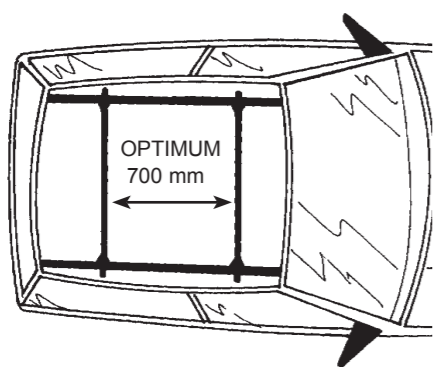

(IT) CENTRARE IL P. TUTTO SUL TETTO
(GB) CENTRE THE UNIVERSAL BAR CARRIER ON THE ROOF
(E) CENTRAR EL PORTAEQUIPAJES SOBRE EL TECHO
(D) LASTENTRÄGER AUF DEM DACH ZENTRIEREN
(F) CENTRER LE PORTE-TOUT SUR LE TOIT
(NL) PLAATS DE UNIVERSELE DRAGER IN HET MIDDEN VAN HET DAK
(P) CENTRAR AS BARRAS PORTA BAGAGENS NO TEJADILHO
(H) HELYEZZE KÖZÉPRE A RUDAKAT
(PL) WYSRODKOWAC BAGAZNIK NA DACHU
(SLO) CENTRIRATI PRTLJAŽNIK NA STREHO
(HR) CENTRIRATI NOSAČE NA KROV

11

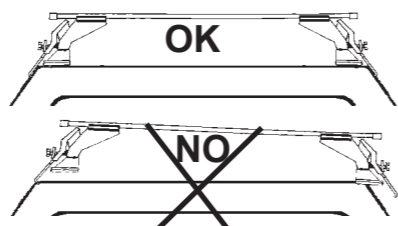

(IT) MODELLI SENZA PREDISPOSIZIONE DELLA CASA AUTO
(GB) CARS WITHOUT PRE-EXISTING FIXING POINT
(E) PARA COCHES SIN PREDISPOSICION DEL FABRICANTE
(D) AUTOS OHNE VOM HERSTELLER VORGESEHENE BEFESTIGUNGSPUNKTE
(F) VOITURES SANS POINTS DE RÉPÈRE PRÉVUS PAR LE CONSTRUCTEUR
(NL) AUTO'S ZONDER DOOR DE FABRIKANT VOORZIENE BEVESTIGINGSPUNTEN
(P) VIATURAS SEM PONTOS DE FIXAÇÃO DO CONSTRUTOR PRÉ-EXISTENTES
(H) FELHÉLYEZÉS GYÁRI JELŐLÉS NÉLKÜLI AUTÓKRA
(PL) SAMOCHODY BEZ PRZEWIDZIANYCH PUNKTOW UMOCOWANIA
(SLO) MODELI Z NEPREDVIDENIM LEŽIŠČEM S STRANI PROIZVAJALCA
(HR) TVORNIČKI NEPRIPREMLJENI MODELI



12

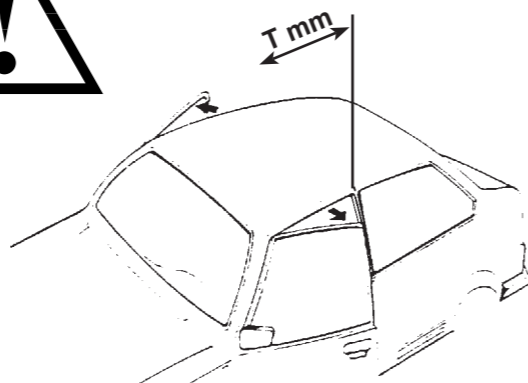

(IT) MODELLI AUTO (GB) CARS (E) COCHES (D) WAGEN (F) VOITURES (NL) AUTO (P) MODELO AUTO (H) AUTÓ TIPUS (PL) MODELE SAMOCHODÓW (SLO) MODELI AVTOMOBILOV (HR) MODELI AUTA	(IT) ANTERIORE (GB) FRONT (E) DELANTERO (D) VORDERE (F) AVANT (NL) VOORSTE G. (P) À FRENTE (H) ELSŐ RÚD (PL) PRZOD (SLO) SPREDAJ (HR) PREDNJI
AUDI A3 3P (03->12)	T (300 mm)

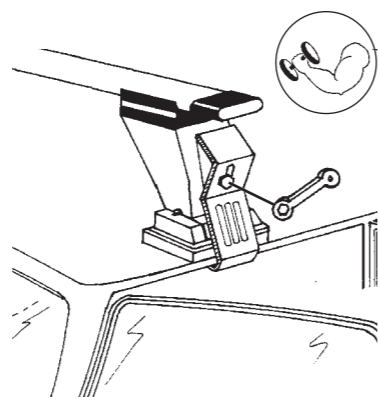

(IT) AVVITARE
(GB) TO SCREW
(E) APRETAR
(D) FESTSCHRAUBEN
(F) VISSER
(NL) VASTSCHROEVEN
(P) APERTAR
(H) MEGHÚZNI
(PL) WKRECIC
(SLO) PRIVITI
(HR) PRIČVRSTITI

(IT) MODELLI CON PREDISPOSIZIONE DELLA CASA AUTO
(GB) CARS WITH PRE-EXISTING FIXING POINT FROM MANUFACTURER
(E) MODELOS CON PREDISPOSICION DEL FABRICANTE
(D) AUTOS MIT VOM HERSTELLER VORGESEHENE BEFESTIGUNGSPUNKTE
(F) VOITURES AVEC POINTS DE RÉPÈRE PRÉVUS PAR LE CONSTRUCTEUR
(NL) AUTO'S MET DOOR DE FABRIKANT VOORZIENE MONTAGEPUNTEN
(P) VIATURAS COM PONTOS DE FIXAÇÃO DO CONSTRUTOR PRÉ-EXISTENTES
(H) FELHÉLYEZÉS GYÁRTÓ ÁLTAL KIJELELT PONTRA
(PL) SAMOCHODY Z PRZEWIDZIANYMI PUNKTAMI UMOCOWANIA
(SLO) MODELI Z PREDVIDENIM LEŽIŠČEM S STRANI PROIZVAJALCA
(HR) TVORNIČKI PRIPREMLJENI MODELI

“À TROUVER SUR LE BATTANT DE LA PORTE OU DANS LE MANUAL TECHNIQUE DE LA VOITURE “

13

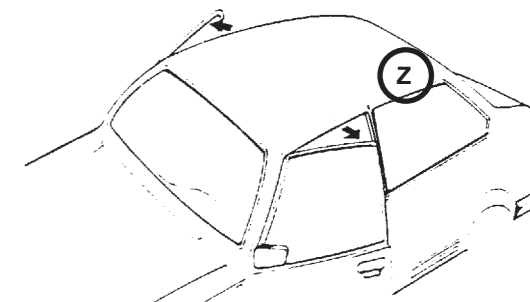

(IT) MODELLI AUTO (GB) CARS (E) COCHES (D) WAGEN (F) VOITURES (NL) AUTO (P) MODELO AUTO (H) AUTÓ TIPUS (PL) MODELE SAMOCHODÓW (SLO) MODELI AVTOMOBILOV (HR) MODELI AUTA	(IT) POSTERIORE (GB) REAR (E) TRASERO (D) HINTERE (F) ARRIERE (NL) ACHTERSTE G. (P) ATRÁS (H) HÁTSÓ RÚD (PL) TYL (SLO) ZADAJ (HR) STRAŽNJI
AUDI A3 3P (03->12)	Z

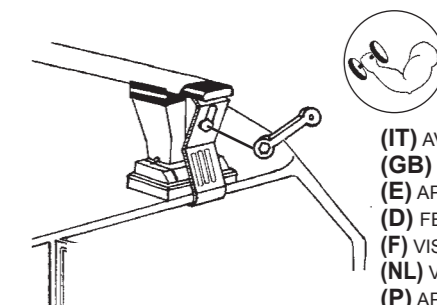

(IT) AVVITARE
(GB) TO SCREW
(E) APRETAR
(D) FESTSCHRAUBEN
(F) VISSER
(NL) VASTSCHROEVEN
(P) APERTAR
(H) MEGHÚZNI
(PL) WKRECIC
(SLO) PRIVITI
(HR) PRIČVRSTITI

(IT) Attenzione: Istruzioni di montaggio per barre in ferro.
(GB) Attention: Mounting instructions for steel bar carriers.
(E) Atención: Instrucciones de montaje para barras portatodo en hierro.
(D) Achtung: Montageanweisungen für Stahl-Lastenträger.
(F) Attention: Notices de montage pour barres de portage en métal.
(NL) Attentie: Handleiding voor dakdragers gemaakt van ijzer.
(P) Atenção: Instrukções de montagem para barras de tejadilho em ferro.
(H) Szerelési utasítás acél tartórudakhoz.
(PL) Uwaga: Instrukcja montażu bagażników wykonanych ze stali.
(SLO) Pozor: Navodila za montažo nosilcev prtljažnika-železnih.
(HR) Uputstvo za montažu željeznih krovnih nosača.

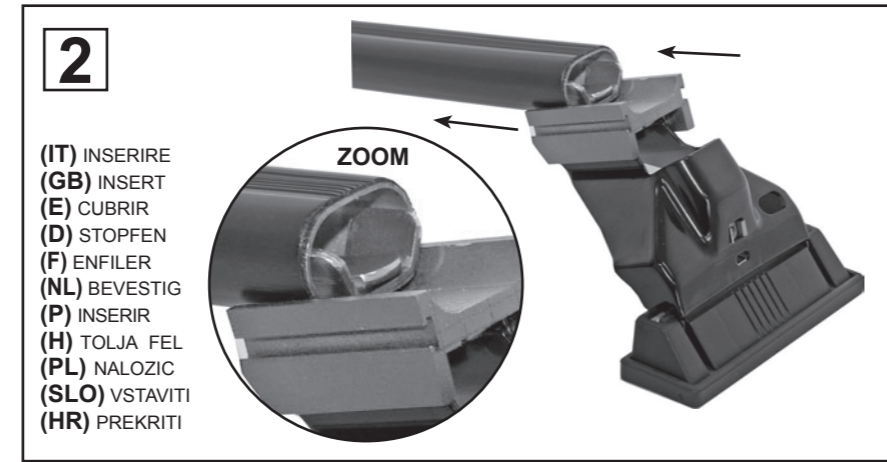
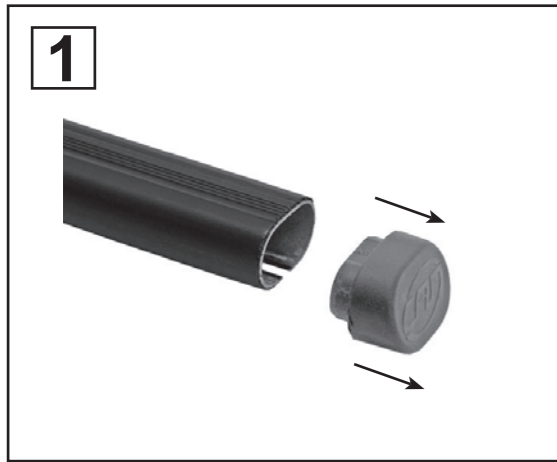

(IT) MODELLI AUTO (GB) CARS (E) COCHES (D) WAGEN (F) VOITURES	(NL) AUTO (P) MODELO AUTO (H) AUTÓ TIPUS (PL) MODELE SAMOCHODÓW (SLO) MODELI AVTOMOBILOV (HR) MODELI AUTA
---	--

(IT) ANTERIORE (GB) FRONT (E) DELANTERO (D) VORDERE (F) AVANT	(NL) VOORSTE G. (P) À FRENTE (H) ELSŐ RÚD (PL) PRZOD (SLO) SPREDAJ (HR) PREDNJI	(IT) POST. (GB) REAR (E) TRASERO (D) HINTERE (F) ARRIERE	(NL) ACHTERSTE G. (P) ATRÁS (H) HÁTSÓ RÚD (PL) TYŁ (SLO) ZADAJ (HR) STRAŽNJI
---	--	--	---

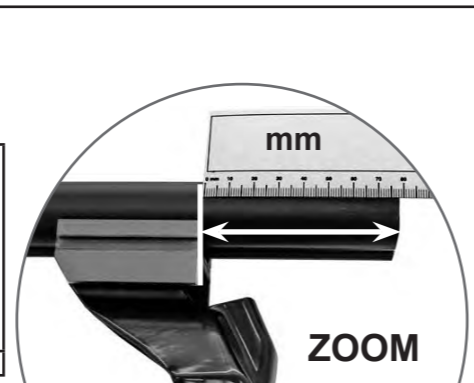

(IT) MISURE PRECISE
(GB) EXACT DIMENSIONS
(E) MEDIDAS CORRECTAS
(D) GENAUE MASSE
(F) MESURES EXACTES
(NL) EXACTE AFMETINGEN
(P) MEDIDAS PRECISAS
(H) PONTOS MÉRET
(PL) DOKŁADNE WYMIARY
(SLO) TOČNE MERE
(HR) PRECIZNE MJERE

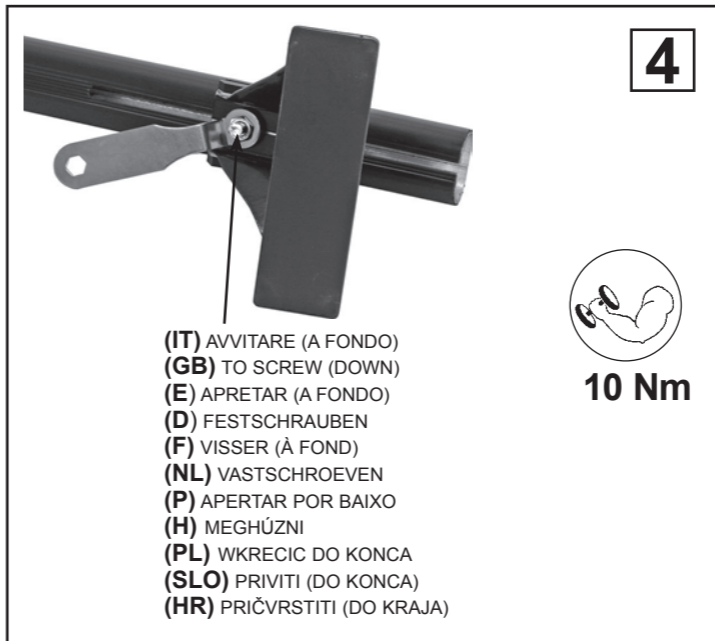
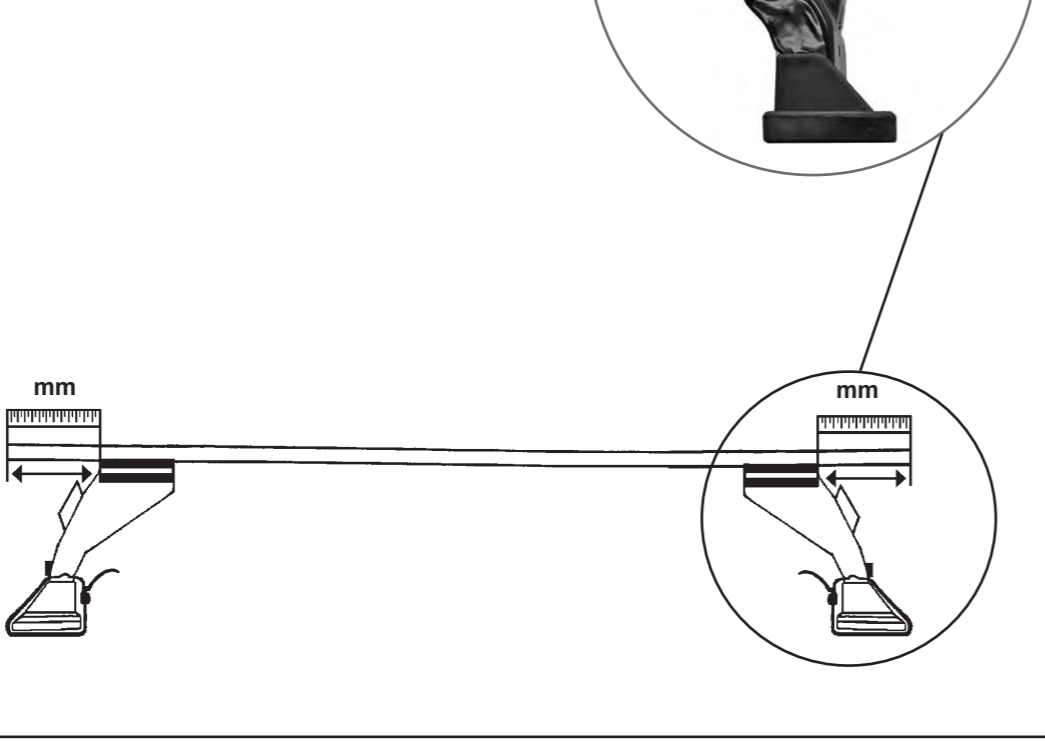

(IT) AVVITARE (A FONDO)
(GB) TO SCREW (DOWN)
(E) APRETAR (A FONDO)
(D) FESTSCHRAUBEN
(F) VISSER (À FOND)
(NL) VASTSCHROEVEN
(P) APERTAR POR BAIXO
(H) MEGHÚZNI
(PL) WKRECIC DO KONCA
(SLO) PRIVITI (DO KONCA)
(HR) PRIČVRSTITI (DO KRAJA)

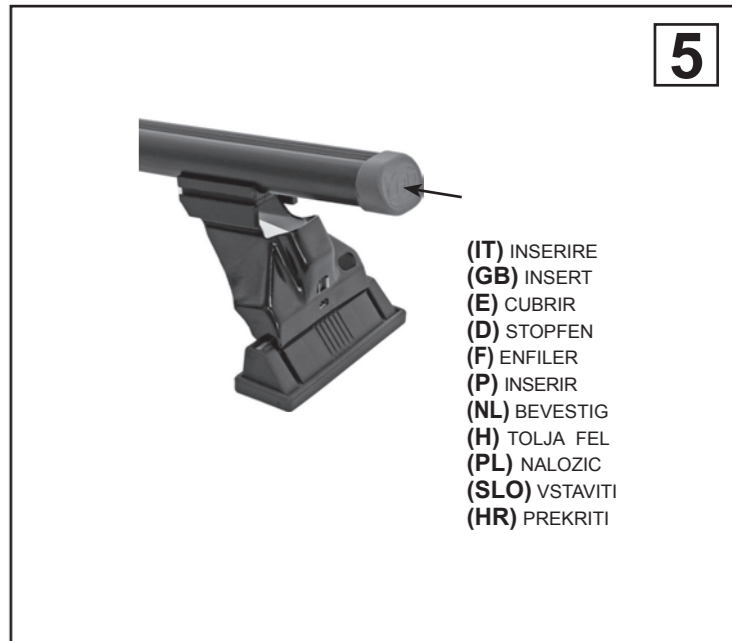

(IT) INSERIRE
(GB) INSERT
(E) CUBRIR
(D) STOPFEN
(F) ENFILER
(P) INSERIR
(NL) BEVESTIG
(H) TOLJA FEL
(PL) NALOZIC
(SLO) VSTAVITI
(HR) PREKRITI

6		(IT) MODELLI AUTO (GB) CARS (E) COCHES (D) WAGEN (F) VOITURES (NL) AUTO (P) MODELO AUTO (H) AUTÓ TIPUS (PL) MODELE SAMOCHODÓW (SLO) MODELI AVTOMOBILOV (HR) MODELI AUTA	(IT) ANTERIORE (GB) FRONT (E) DELANTERO (D) VORDERE (F) AVANT (NL) VOORSTE G. (P) À FRENTE (H) ELSŐ RÚD (PL) PRZOD (SLO) SPREDAJ (HR) PREDNJI	(IT) POSTERIORE (GB) REAR (E) TRASERO (D) HINTERE (F) ARRIERE (NL) ACHTERSTE G. (P) ATRÁS (H) HÁTSÓ RÚD (PL) TYŁ (SLO) ZADAJ (HR) STRAŽNJI
		AUDI A3 3P (03->12)	5	54P

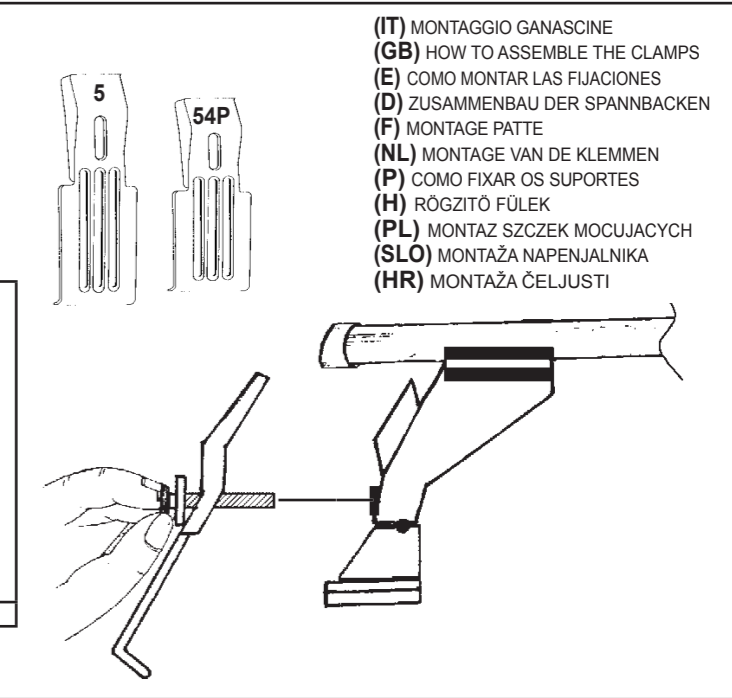

(IT) MONTAGGIO GANASCINE
(GB) HOW TO ASSEMBLE THE CLAMPS
(E) COMO MONTAR LAS FIJACIONES
(D) ZUSAMMENBAU DER SPANNBACKEN
(F) MONTAGE PATTE
(NL) MONTAGE VAN DE KLEMMEN
(P) COMO FIXAR OS SUPORTES
(H) RÖGZÍTŐ FÜLEK
(PL) MONTAZ SZCZEK MOCUJACYCH
(SLO) MONTAŽA NAPENJALNIKA
(HR) MONTAŽA ČELJUSTI

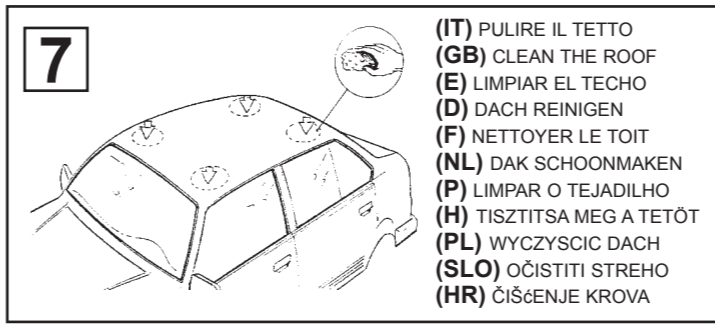

(IT) PULIRE IL TETTO
(GB) CLEAN THE ROOF
(E) LIMPIAR EL TECHO
(D) DACH REINIGEN
(F) NETTOYER LE TOIT
(NL) DAK SCHOONMAKEN
(P) LIMPAR O TEJADILHO
(H) TISZTÍTSA MEG A TETŐT
(PL) WYCZYSCIC DACH
(SLO) OČISTITI STREHO
(HR) ČIŠĆENJE KROVA

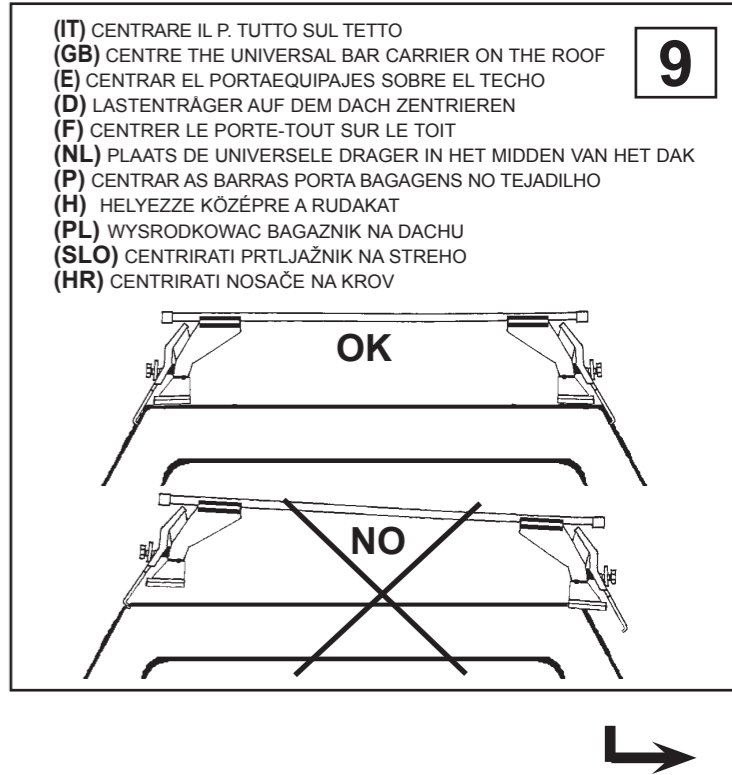

(IT) CENTRARE IL P. TUTTO SUL TETTO
(GB) CENTRE THE UNIVERSAL BAR CARRIER ON THE ROOF
(E) CENTRAR EL PORTAEQUIPAJES SOBRE EL TECHO
(D) LASTENTRÄGER AUF DEM DACH ZENTRIEREN
(F) CENTRER LE PORTE-TOUT SUR LE TOIT
(NL) PLAATS DE UNIVERSELE DRAGER IN HET MIDDEN VAN HET DAK
(P) CENTRAR AS BARRAS PORTA BAGAGENS NO TEJADILHO
(H) HELYEZZE KÖZÉPRE A RUDAKAT
(PL) WYSRODKOWAC BAGAZNIK NA DACHU
(SLO) CENTRIRATI PRTLJAŽNIK NA STREHO
(HR) CENTRIRATI NOSAČE NA KROV

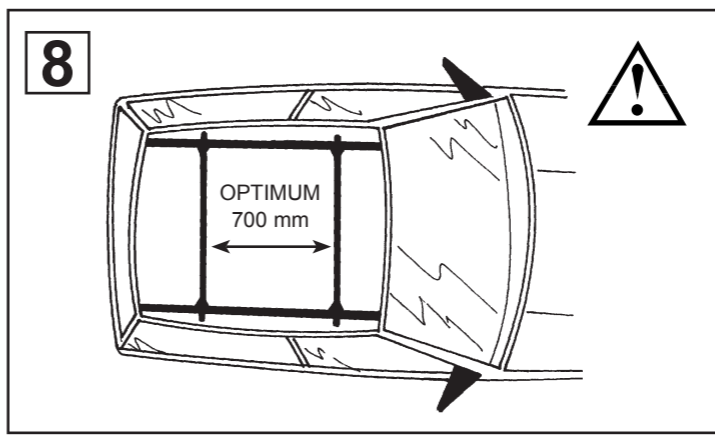

8

OPTIMUM
700 mm



(IT) MODELLI SENZA PREDISPOSIZIONE DELLA CASA AUTO
 (GB) CARS WITHOUT PRE-EXISTING FIXING POINT
 (E) PARA COCHES SIN PREDISPOSICION DEL FABRICANTE
 (D) AUTOS OHNE VOM HERSTELLER VORGESEHENE BEFESTIGUNGSPUNKTE
 (F) VOITURES SANS POINTS DE RÉPÈRE PRÉVUS PAR LE CONSTRUCTEUR
 (NL) AUTO'S ZONDER DOOR DE FABRIKANT VOORZIENE BEVESTIGINGSPUNTEN
 (P) VIATURAS SEM PONTOS DE FIXAÇÃO DO CONSTRUTOR PRÉ-EXISTENTES
 (H) FELHELYEZÉS GYÁRI JELÖLÉS NÉLKÜLI AUTÓKRA
 (PL) SAMOCHODY BEZ PRZEWDZIANYCH PUNKTOW UMOCOWANIA
 (SLO) MODELI Z NEPREDVIDENIM LEŽIŠČEM S STRANI PROIZVAJALCA
 (HR) TVORNIČKI NEPRIPREMLJENI MODELI

10

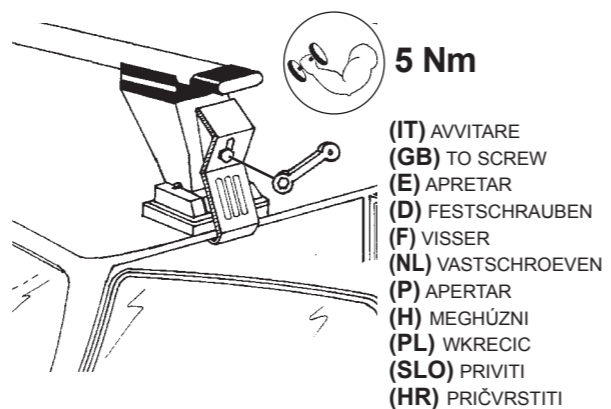
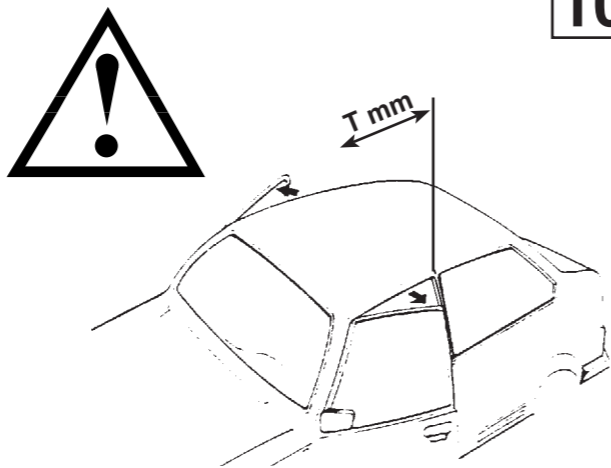

5 Nm

(IT) AVVITARE
 (GB) TO SCREW
 (E) APRETAR
 (D) FESTSCHRAUBEN
 (F) VISSER
 (NL) VASTSCHROEVEN
 (P) APERTAR
 (H) MEGHÚZNI
 (PL) WKRECIC
 (SLO) PRIVITI
 (HR) PRIČVRSTITI

(IT) MODELLI AUTO	(IT) ANTERIORE
(GB) CARS	(GB) FRONT
(E) COCHES	(E) DELANTERO
(D) WAGEN	(D) VORDERE
(F) VOITURES	(F) AVANT
(NL) AUTO	(NL) VOORSTE G.
(P) MODELO AUTO	(P) À FRENTE
(H) AUTÓ TIPUS	(H) ELSŐ RÚD
(PL) MODELE SAMOCHODÓW	(PL) PRZOD
(SLO) MODELI AVTOMOBILOV	(SLO) SPREDAJ
(HR) MODELI AUTA	(HR) PREDNJI
AUDI A3 3P (03->12)	T (300 mm)

(IT) MODELLI CON PREDISPOSIZIONE DELLA CASA AUTO
 (GB) CARS WITH PRE-EXISTING FIXING POINT FROM MANUFACTURER
 (E) MODELOS CON PREDISPOSICION DEL FABRICANTE
 (D) AUTOS MIT VOM HERSTELLER VORGESEHENE BEFESTIGUNGSPUNKTE
 (F) VOITURES AVEC POINTS DE RÉPÈRE PRÉVUS PAR LE CONSTRUCTEUR
 (NL) AUTO'S MET DOOR DE FABRIKANT VOORZIENE MONTAGEPUNTEN
 (P) VIATURAS COM PONTOS DE FIXAÇÃO DO CONSTRUTOR PRÉ-EXISTENTES
 (H) FELHELYEZÉS GYÁRTÓ ÁLTAL KIJELÖLT PONTRA
 (PL) SAMOCHODY Z PRZEWDZIANYMI PUNKTAMI UMOCOWANIA
 (SLO) MODELI Z PREDVIDENIM LEŽIŠČEM S STRANI PROIZVAJALCA
 (HR) TVORNIČKI PRIPREMLJENI MODELI

“À TROUVER SUR LE BATTANT DE LA PORTE OU
 DANS LE MANUAL TECHNIQUE DE LA VOITURE “

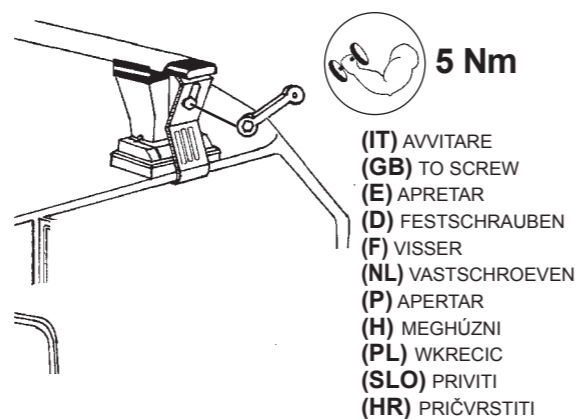
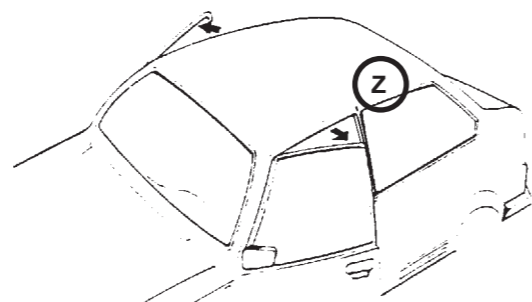

5 Nm

(IT) AVVITARE
 (GB) TO SCREW
 (E) APRETAR
 (D) FESTSCHRAUBEN
 (F) VISSER
 (NL) VASTSCHROEVEN
 (P) APERTAR
 (H) MEGHÚZNI
 (PL) WKRECIC
 (SLO) PRIVITI
 (HR) PRIČVRSTITI

(IT) MODELLI AUTO	(IT) POSTERIORE
(GB) CARS	(GB) REAR
(E) COCHES	(E) TRASERO
(D) WAGEN	(D) HINTERE
(F) VOITURES	(F) ARRIERE
(NL) AUTO	(NL) ACHTERSTE G.
(P) MODELO AUTO	(P) ATRÁS
(H) AUTÓ TIPUS	(H) HÁTSÓ RÚD
(PL) MODELE SAMOCHODÓW	(PL) TYL
(SLO) MODELI AVTOMOBILOV	(SLO) ZADAJ
(HR) MODELI AUTA	(HR) STRAŽNJI
AUDI A3 3P (03->12)	Z

40073 PARTS LIST

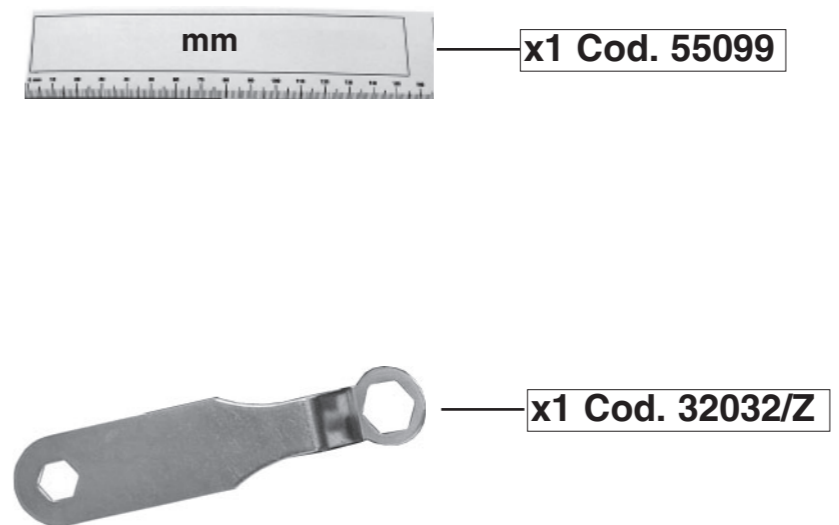
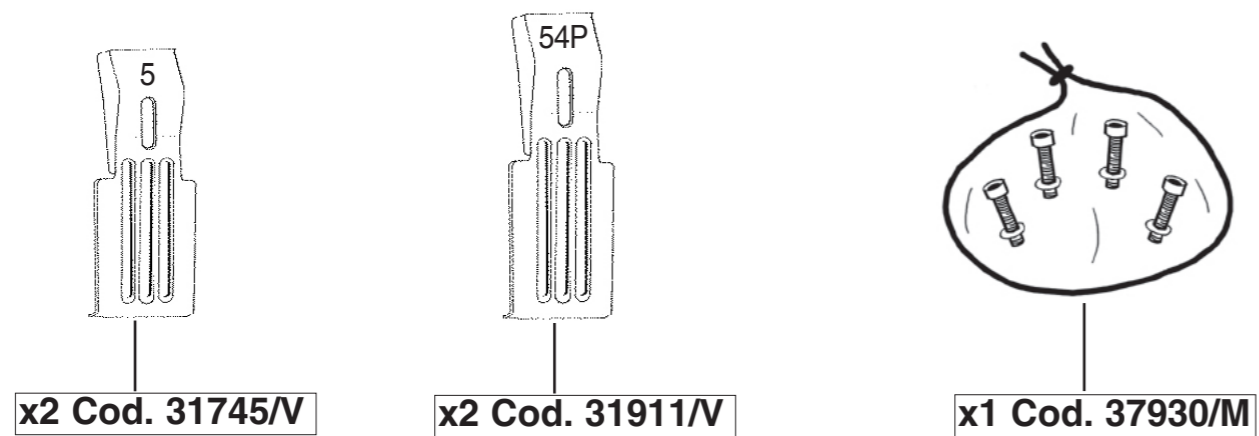
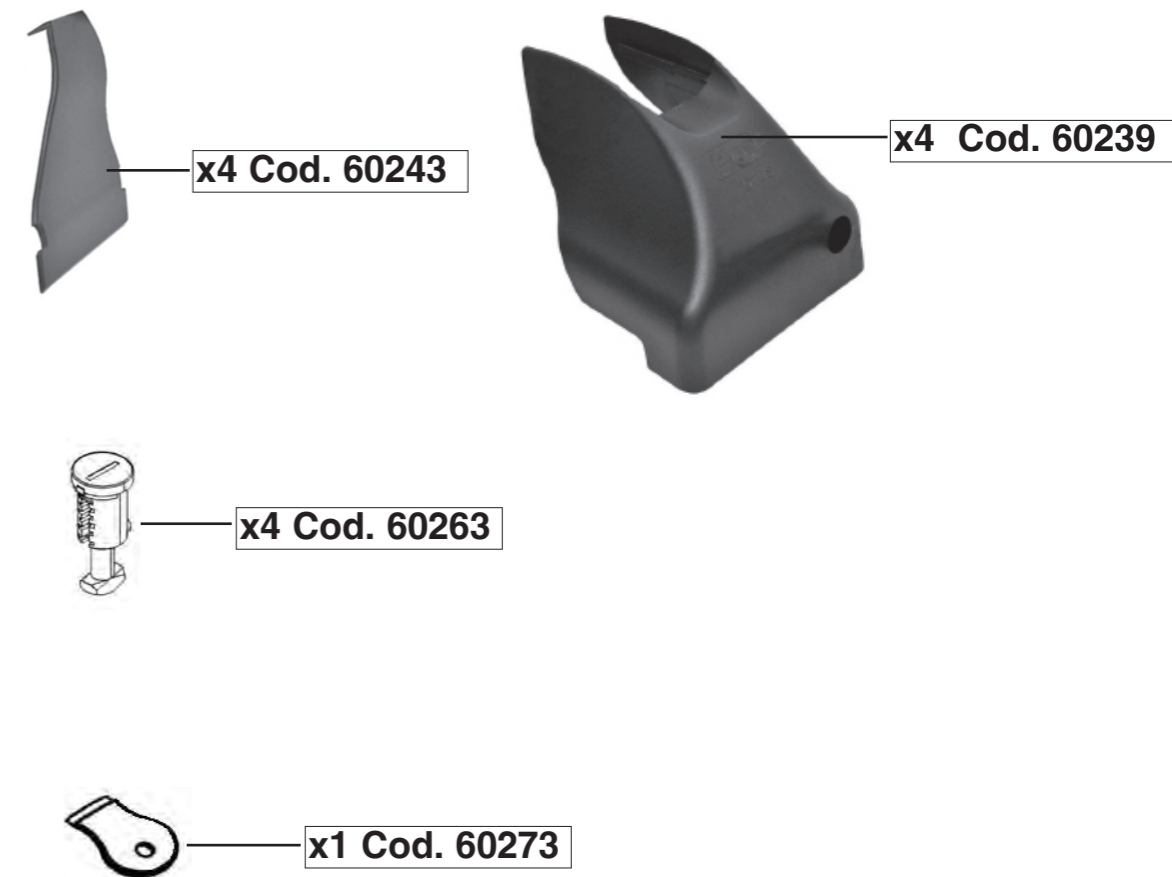
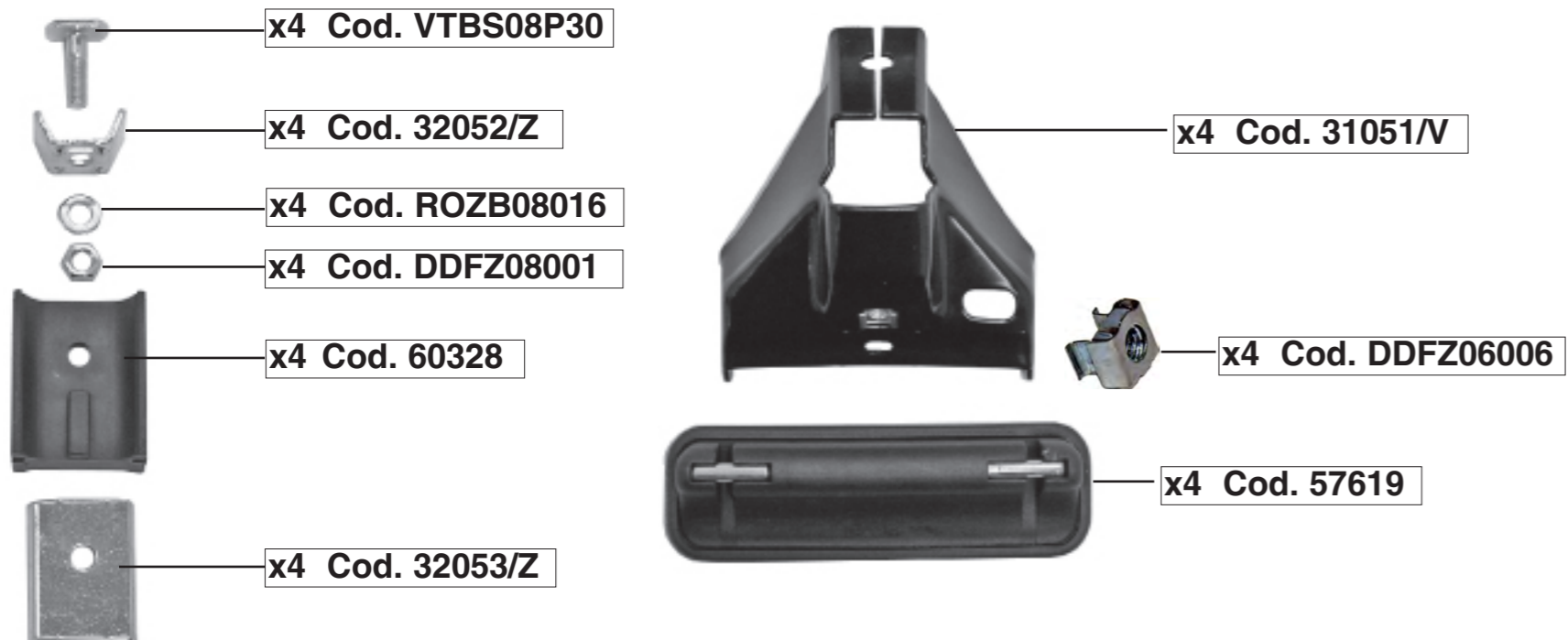

COVER TOTUS

(IT) ISTRUZIONI DI MONTAGGIO (GB) FITTING INSTRUCTIONS (E) INSTRUCCIONES PARA SU MONTAJE
(D) MONTAGEANWEISUNGEN (F) INSTRUCTIONS DE MONTAGE (NL) MONTAGE INSTRUCTIES (P) INSTRUÇÕES DE MONTAGEM
(H) SZERELÉSI UTASÍTÁS (PL) INSTRUKCJA MONTAŻU (SLO) NAVODILA O MONTAŽI (HR) UPUTE ZA MONTAŽU.

1



(IT) INSERIRE
(GB) INSERT
(E) CUBRIR
(D) STOPFEN
(F) ENFILER
(P) INSERIR
(NL) BEVESTIG
(H) TOLJA FEL
(PL) NALOZIC
(SLO) VSTAVITI
(HR) PREKRITI



2

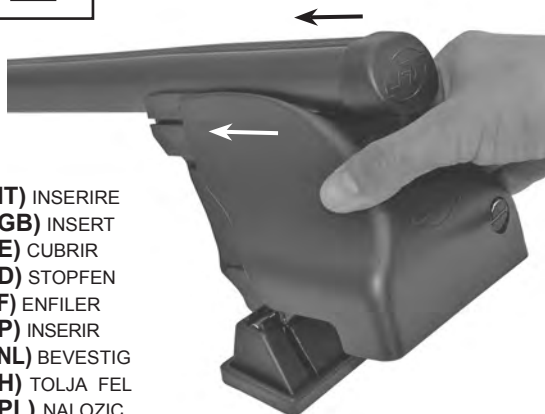

(IT) INSERIRE
(GB) INSERT
(E) CUBRIR
(D) STOPFEN
(F) ENFILER
(P) INSERIR
(NL) BEVESTIG
(H) TOLJA FEL
(PL) NALOZIC
(SLO) VSTAVITI
(HR) PREKRITI

3



4



(IT) INSERIRE
(GB) INSERT
(E) CUBRIR
(D) STOPFEN
(F) ENFILER
(P) INSERIR
(NL) BEVESTIG
(H) TOLJA FEL
(PL) NALOZIC
(SLO) VSTAVITI
(HR) PREKRITI



NO PER ART. 40102 - 40115 - 40119