

(IT) Attenzione: Istruzioni di montaggio per barre in alluminio.
(GB) Attention: Mounting instructions for aluminium bar carriers.
(E) Atención: Instrucciones de montaje para barras portatodo en aluminio.
(D) Achtung: Montageanweisungen für Aluminium-Lastenträger.
(F) Attention: Notices de montage pour barres de portage en aluminium.
(NL) Attentie: Handleiding voor dakdragers gemaakt van aluminium.
(P) Atenção: Instruções de montagem para barras de tejadilho em alumínio.
(H) Szerelési utasítás alumínium tartórudakhoz.
(PL) Uwaga: Instrukcja montażu bagażników wykonanych ze aluminium.
(SLO) Pozor: Navodila za montažo nosilcev prtljažnika - aluminijastih.
(HR) Uputstvo za montažu aluminijaskih nosača.

1 **FIAT: IDEA NO RAILS (05->)**
LANCIA: MUSA NO RAILS (05->) con e senza tetto in vetro / with and without glass roof / avec et sauf toit en verre / mit und ohne Glasdach

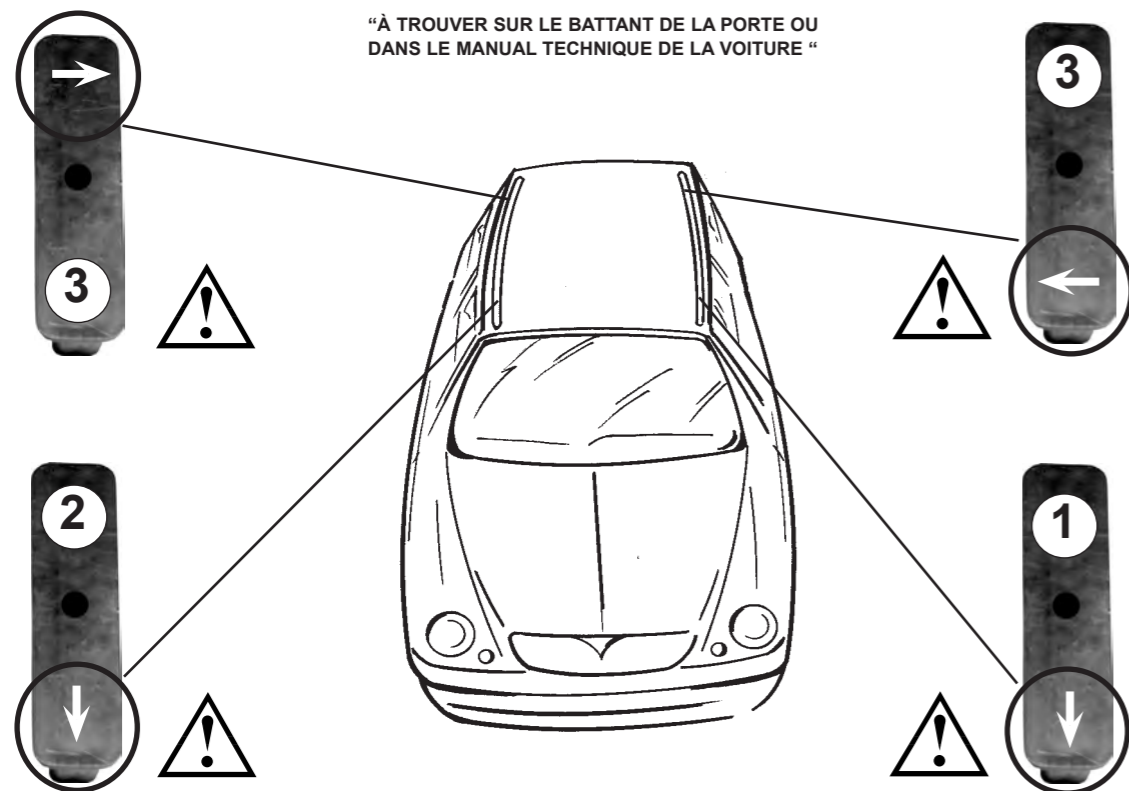
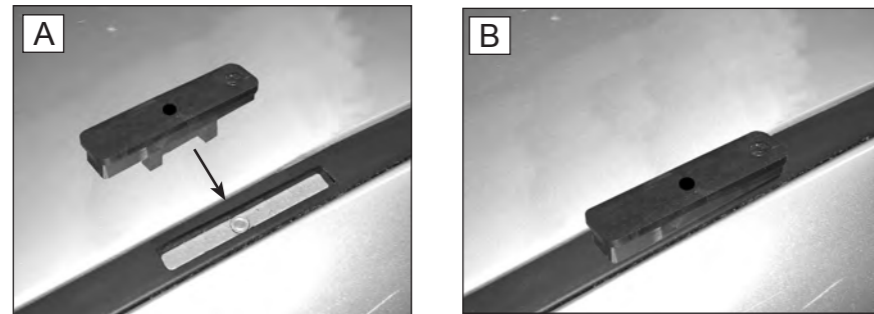

2 **ZOOM**

(A)
(IT) SVITARE
(GB) UNSCREW
(E) AFLOJAR
(D) ABSCHRAUBEN
(F) DEVISSER
(NL) OPENSCHROEVEN
(P) DESAPARAFUSAR
(H) KICSÁVARNI
(PL) WYKRECIĆ
(SLO) ODVITI
(HR) ODVITI

(B)

(C)

(D)

(IT) INSERIRE
(GB) INSERT
(E) CUBRIR
(D) STOPFEN
(F) ENFILER
(NL) BEVESTIG

(P) INSERIR
(H) TOLJA FEL
(PL) NALOZIC
(SLO) VSTAVITI
(HR) PREKRITI

(IT) AVVITARE
(GB) TO SCREW
(E) APRETAR
(D) FESTSCHRAUBEN
(F) VISSER
(NL) VASTSCHROEVEN

(P) APERTAR
(H) MEGHÚZNI
(PL) WKRECIĆ
(SLO) PRIVITI
(HR) PRIČVRSTITI

3

ZOOM

(IT) INSERIRE
(GB) INSERT
(E) CUBRIR
(D) STOPFEN
(F) ENFILER
(NL) BEVESTIG

(P) INSERIR
(H) TOLJA FEL
(PL) NALOZIC
(SLO) VSTAVITI
(HR) PREKRITI

4

(IT) INSERIRE
(GB) INSERT
(E) CUBRIR
(D) STOPFEN
(F) ENFILER
(P) INSERIR
(NL) BEVESTIG
(H) TOLJA FEL
(PL) NALOZIC
(SLO) VSTAVITI
(HR) PREKRITI

(A)

(B)

5

(IT) TAGLIARE
(GB) TO CUT
(E) CORTAR
(D) SCHNEIDEN
(F) COUPER
(NL) SNIJDEN
(P) CORTAR
(H) ELVÁGNI
(PL) OBCIĄC
(SLO) ODREZATI
(HR) ODREZATI

(A)

(B)

(IT) INSERIRE
(GB) INSERT
(E) CUBRIR
(D) STOPFEN
(F) ENFILER
(P) INSERIR
(NL) BEVESTIG
(H) TOLJA FEL
(PL) NALOZIC
(SLO) VSTAVITI
(HR) PREKRITI

6

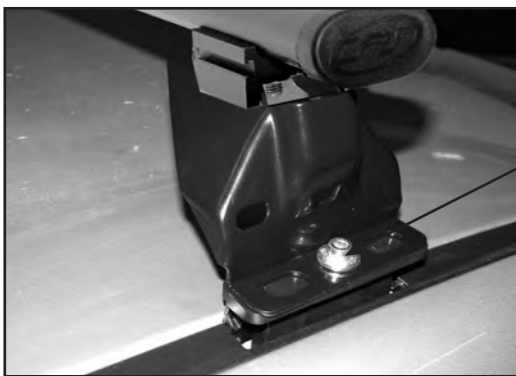

(IT) AVVITARE
(GB) TO SCREW
(E) APRETAR
(D) FESTSCHRAUBEN
(F) VISSER
(NL) VASTSCHROEVEN
(P) APERTAR
(H) MEGHÚZNI
(PL) WKRECIC
(SLO) PRIVITI
(HR) PRIČVRSTITI



5 Nm



(IT) POSTERIORE
(GB) REAR
(E) TRASERO
(D) HINTERE
(F) ARRIERE
(NL) ACHTERSTE G.
(P) ATRÁS
(H) HÁTSÓ RÚD
(PL) TYŁ
(SLO) ZADAJ
(HR) STRAŽNJI

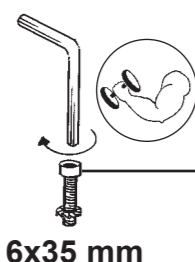

5 Nm

6x35 mm

(IT) Modello con tetto in vetro
(GB) Model with glass roof
(E) Modelo con techo de cristal
(D) modell mit Glasdach
(F) Modèle avec toit en verre

6x40 mm

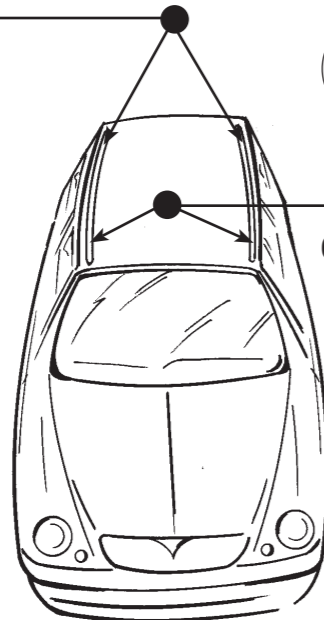

5 Nm

6x40 mm

(IT) ANTERIORE
(GB) FRONT
(E) DELANTERO
(D) VORDERE
(F) AVANT
(NL) VOORSTE G.
(P) À FRENTE
(H) ELSŐ RÚD
(PL) PRZOD
(SLO) SPREDAJ
(HR) PREDNJI

(IT) Modello con tetto in vetro
(GB) Model with glass roof
(E) Modelo con techo de cristal
(D) modell mit Glasdach
(F) Modèle avec toit en verre

6x50 mm



(IT) CENTRARE IL P. TUTTO SUL TETTO
(GB) CENTRE THE UNIVERSAL BAR CARRIER ON THE ROOF
(E) CENTRAR EL PORTAEQUIPAJES SOBRE EL TECHO
(D) LASTENTRÄGER AUF DEM DACH ZENTRIEREN
(F) CENTRER LE PORTE-TOUT SUR LE TOIT
(NL) PLAATS DE UNIVERSELE DRAGER IN HET MIDDEN VAN HET DAK
(P) CENTRAR AS BARRAS PORTA BAGAGENS NO TEJADILHO
(H) HELYEZZE KÖZÉPRE A RUDAKAT
(PL) WYSRODKOWAC BAGAŻNIK NA DACHU
(SLO) CENTRIRATI PRTLJAŽNIK NA STREHO
(HR) CENTRIRATI NOSAČE NA KROV

7

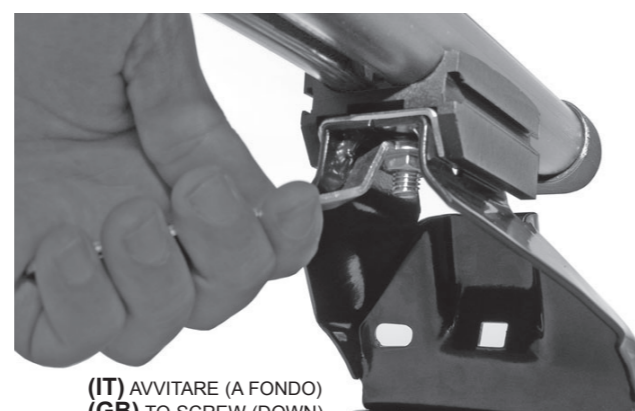
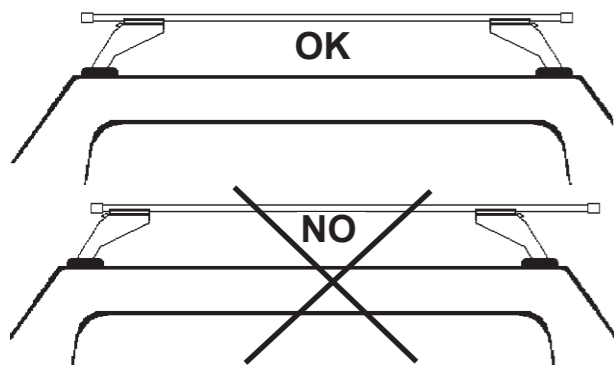

8

(IT) AVVITARE (A FONDO)
(GB) TO SCREW (DOWN)
(E) APRETAR (A FONDO)
(D) FESTSCHRAUBEN
(F) VISSER (À FOND)
(NL) VASTSCHROEVEN
(P) APERTAR POR BAIXO
(H) MEGHÚZNI
(PL) WKRECIC DO KONCA
(SLO) PRIVITI (DO KONCA)
(HR) PRIČVRSTITI (DO KRAJA)



10 Nm

9

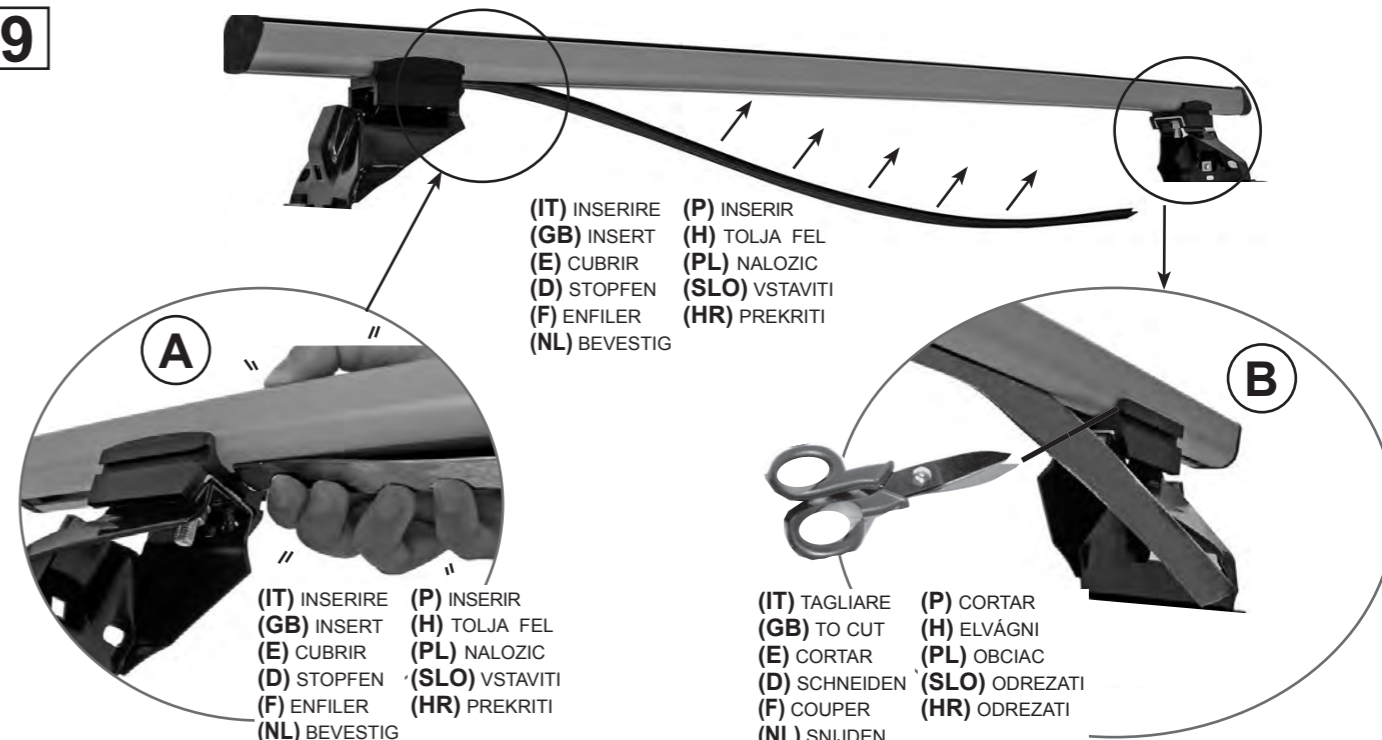

(IT) INSERIRE
(GB) INSERT
(E) CUBRIR
(D) STOPFEN
(F) ENFILER
(NL) BEVESTIG

(P) INSERIR
(H) TOLJA FEL
(PL) NALOZIC
(SLO) VSTAVITI
(HR) PREKRITI

(IT) INSERIRE
(GB) INSERT
(E) CUBRIR
(D) STOPFEN
(F) ENFILER
(NL) BEVESTIG

(P) INSERIR
(H) TOLJA FEL
(PL) NALOZIC
(SLO) VSTAVITI
(HR) PREKRITI

(IT) TAGLIARE
(GB) TO CUT
(E) CORTAR
(D) SCHNEIDEN
(F) COUPER
(NL) SNIJDEN

(P) CORTAR
(H) ELVÁGNI
(PL) OBCIAC
(SLO) ODREZATI
(HR) ODREZATI

10

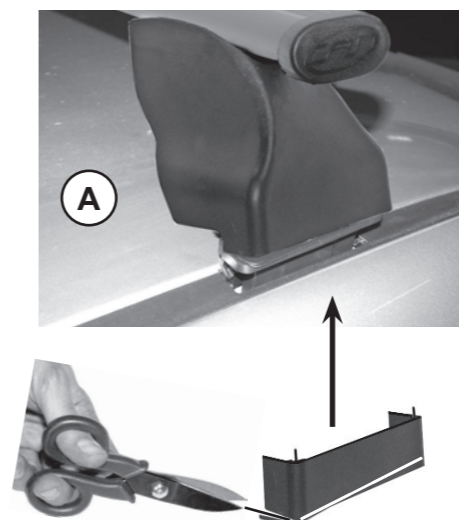



(IT) INSERIRE
(GB) INSERT
(E) CUBRIR
(D) STOPFEN
(F) ENFILER
(P) INSERIR
(NL) BEVESTIG
(H) TOLJA FEL
(PL) NALOZIC
(SLO) VSTAVITI
(HR) PREKRITI

A

B







(IT) **Attenzione:** Istruzioni di montaggio per barre in ferro.
 (GB) **Attention:** Mounting instructions for steel bar carriers.
 (E) **Atencion:** Instrucciones de montaje para barras portatodo en hierro.
 (D) **Achtung:** Montageanweisungen für Stahl-Lastenträger.
 (F) **Attention:** Notices de montage pour barres de portage en métal.
 (NL) **Attentie:** Handleiding voor dakdragers gemaakt van ijzer.
 (P) **Atenção:** Instrukções de montagem para barras de tejadilho em ferro.
 (H) **Szerelési utasítás** acél tartórudakhoz.
 (PL) **Uwaga:** Instrukcja montażu bagażników wykonanych ze stali.
 (SLO) **Pozor:** Navodila za montažo nosilcev prtljažnika-železnih.
 (HR) **Uputstvo za** montažu željeznih krovnih nosača.

1

FIAT: IDEA NO RAILS (05->)
LANCIA: MUSA (05->) NO RAILS con e senza tetto in vetro / with and without glass roof / avec et sauf toit en verre / mit und ohne Glasdach

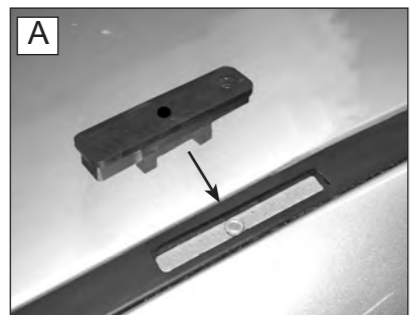

A

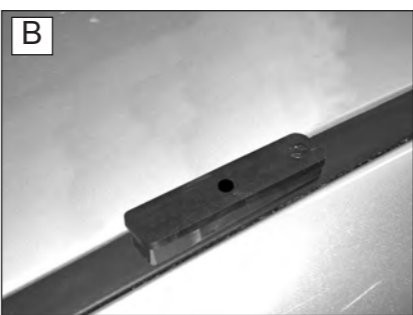

B

“À TROUVER SUR LE BATTANT DE LA PORTE OU DANS LE MANUAL TECHNIQUE DE LA VOITURE “

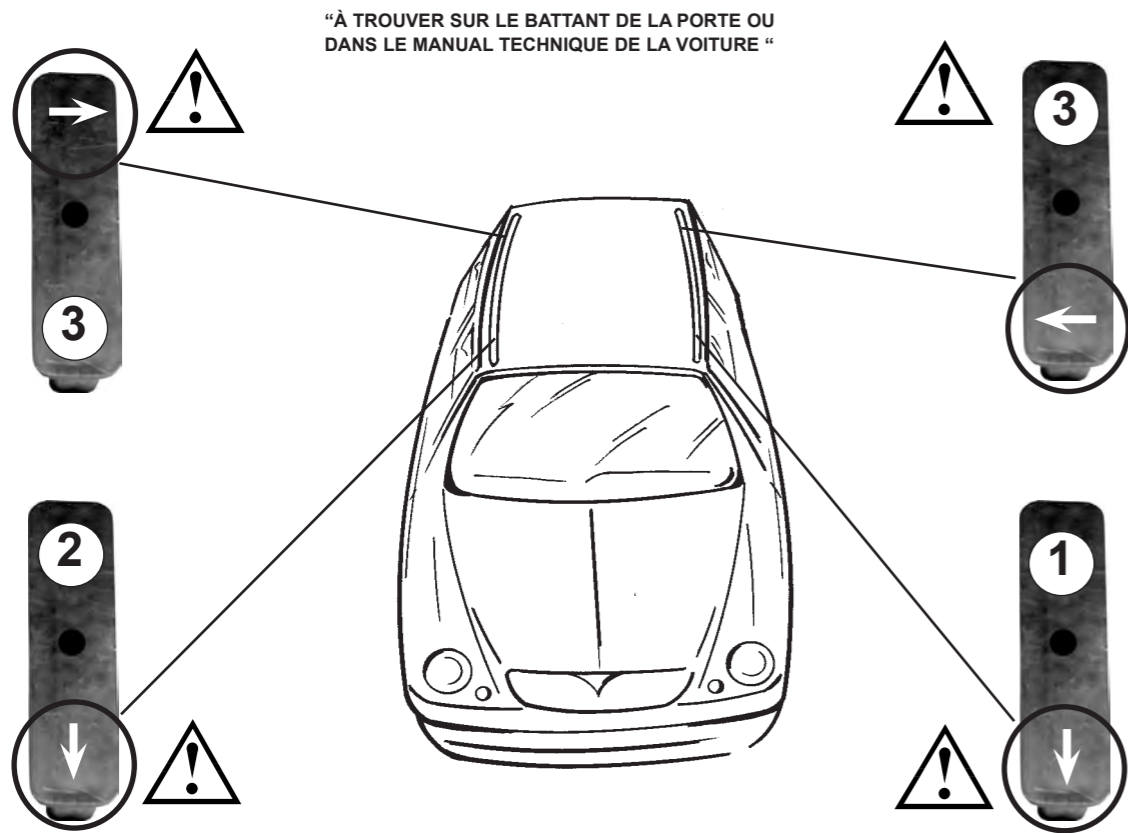

2

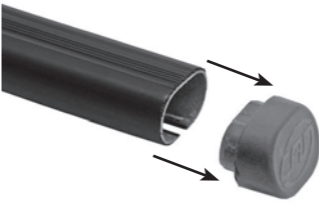

3

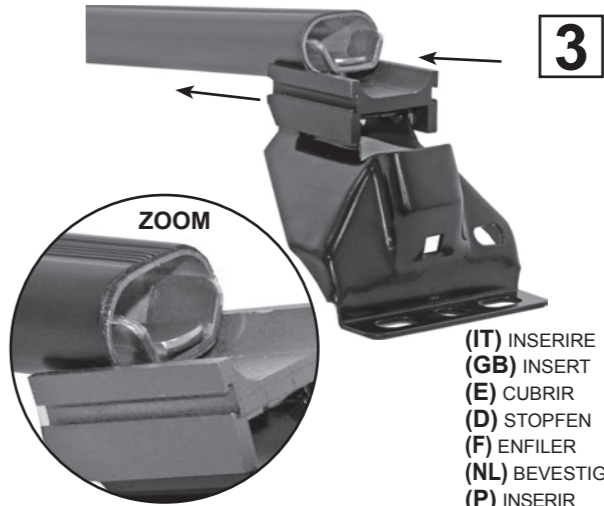

(IT) INSERIRE
 (GB) INSERT
 (E) CUBRIR
 (D) STOPFEN
 (F) ENFILER
 (NL) BEVESTIG
 (P) INSERIR
 (H) TOLJA FEL
 (PL) NALOZIC
 (SLO) VSTAVITI
 (HR) PREKRITI

4

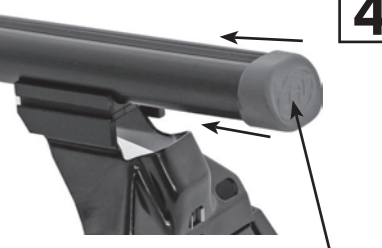

(IT) INSERIRE
 (GB) INSERT
 (E) CUBRIR
 (D) STOPFEN
 (F) ENFILER
 (NL) BEVESTIG
 (P) INSERIR
 (H) TOLJA FEL
 (PL) NALOZIC
 (SLO) VSTAVITI
 (HR) PREKRITI

5



(IT) MODELLI CON PREDISPOSIZIONE DELLA CASA AUTO
 (GB) CARS WITH PRE-EXISTING FIXING POINT FROM MANUFACTURER
 (E) MODELOS CON PREDISPOSICION DEL FABRICANTE
 (D) AUTOS MIT VOM HERSTELLER VORGESEHENE BEFESTIGUNGSPUNKTE
 (F) VOITURES AVEC POINTS DE RÉPÈRE PREVUS PAR LE CONSTRUCTEUR
 (NL) AUTO'S MET DOOR DE FABRIKANT VOORZIENE MONTAGEPUNTEN
 (P) VIATURAS COM PONTOS DE FIXAÇÃO DO CONSTRUTOR PRÉ-EXISTENTES
 (H) FELHÉLYEZÉS GYÁRTÓ ÁLTAL KIJELÖLT PONTRA
 (PL) SAMOCHODY Z PRZEWIDZIANYMI PUNKTAMI UMOCOWANIA
 (SLO) MODELI Z PREDVIDENIM LEŽIŠČEM S STRANI PROIZVAJALCA
 (HR) TVORNIČKI PRIPREMLJENI MODELI

(IT) AVVITARE
 (GB) TO SCREW
 (E) APRETAR
 (D) FESTSCHRAUBEN
 (F) VISSER
 (NL) VASTSCHROEVEN
 (P) APERTAR
 (H) MEGHÚZNI
 (PL) WKRECIĆ
 (SLO) PRIVITI
 (HR) PRIČVRSTITI

5 Nm



(IT) POSTERIORE
 (GB) REAR
 (E) TRASERO
 (D) HINTERE
 (F) ARRIERE
 (NL) ACHTERSTE G.
 (P) ATRÁS
 (H) HÁTSÓ RÚD
 (PL) TYŁ
 (SLO) ZADAJ
 (HR) STRAŽNJI

6x35 mm

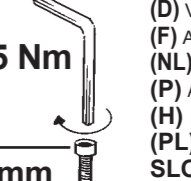

(IT) Modello con tetto in vetro
 (GB) Model with glass roof
 (E) Modelo con techo de cristal
 (D) modell mit Glasdach
 (F) Modèle avec toit en verre

6x40 mm



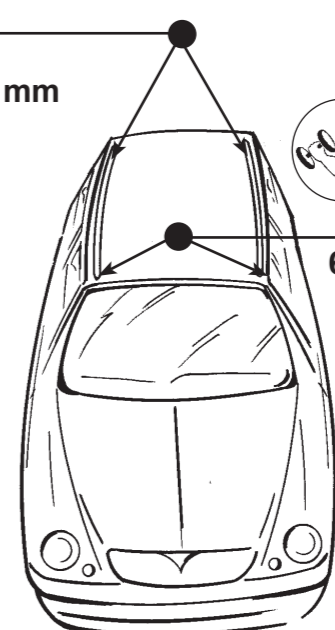

(IT) ANTERIORE
 (GB) FRONT
 (E) DELANTERO
 (D) VORDERE
 (F) AVANT
 (NL) VOORSTE G.
 (P) À FRENTE
 (H) ELSÓ RÚD
 (PL) PRZOD
 (SLO) SPREDAJ
 (HR) PREDNJI

6x40 mm

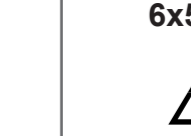

(IT) Modello con tetto in vetro
 (GB) Model with glass roof
 (E) Modelo con techo de cristal
 (D) modell mit Glasdach
 (F) Modèle avec toit en verre

6x50 mm



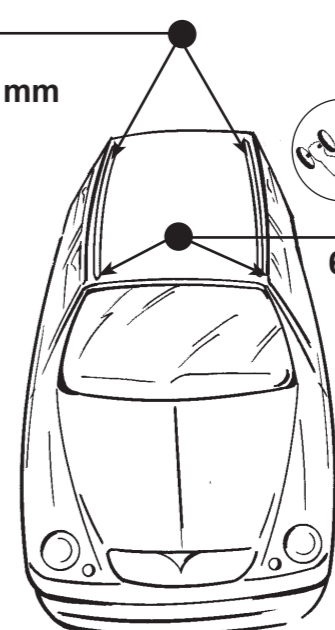

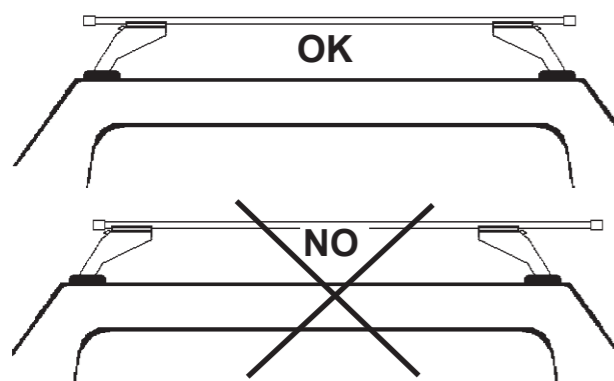
6

(IT) CENTRARE IL P. TUTTO SUL TETTO
 (GB) CENTRE THE UNIVERSAL BAR CARRIER ON THE ROOF
 (E) CENTRAR EL PORTAEQUIPAJES SOBRE EL TECHO
 (D) LASTENTRÄGER AUF DEM DACH ZENTRIEREN
 (F) CENTRER LE PORTE-TOUT SUR LE TOIT
 (NL) PLAATS DE UNIVERSELE DRAGER IN HET MIDDE VAN HET DAK
 (P) CENTRAR AS BARRAS PORTA BAGAGENS NO TEJADILHO
 (H) HELYEZSE KÖZÉPRE A RUDAKAT
 (PL) WYSRODKOWAC BAGAZNIK NA DACHU
 (SLO) CENTRIRATI PRTLJAŽNIK NA STREHO
 (HR) CENTRIRATI NOSAČE NA KROV

7**10 Nm**

(IT) AVVITARE (A FONDO)
 (GB) TO SCREW (DOWN)
 (E) APRETAR (A FONDO)
 (D) FESTSCHRAUBEN
 (F) VISSER (À FOND)
 (NL) VASTSCHROEVEN
 (P) APERTAR POR BAIXO
 (H) MEGHÚZNI
 (PL) WKRECIC DO KONCA
 (SLO) PRIVITI (DO KONCA)
 (HR) PRIČVRSTITI (DO KRAJA)

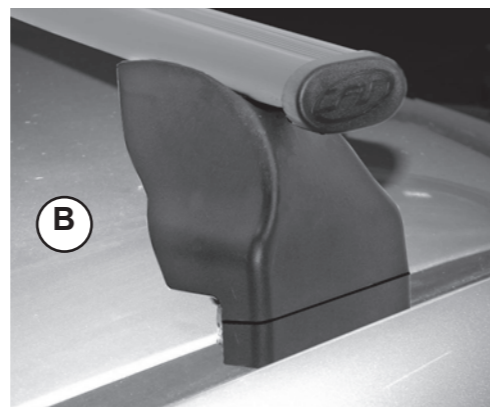
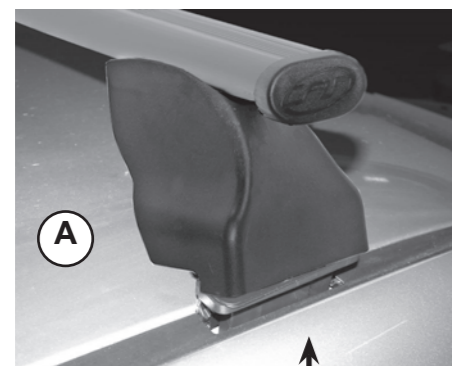
8

(IT) INSERIRE
 (GB) INSERT
 (E) CUBRIR
 (D) STOPFEN
 (F) ENFILER
 (P) INSERIR
 (NL) BEVESTIG
 (H) TOLJA FEL
 (PL) NALOZIC
 (SLO) VSTAVITI
 (HR) PREKRITI

40084 PARTS LIST

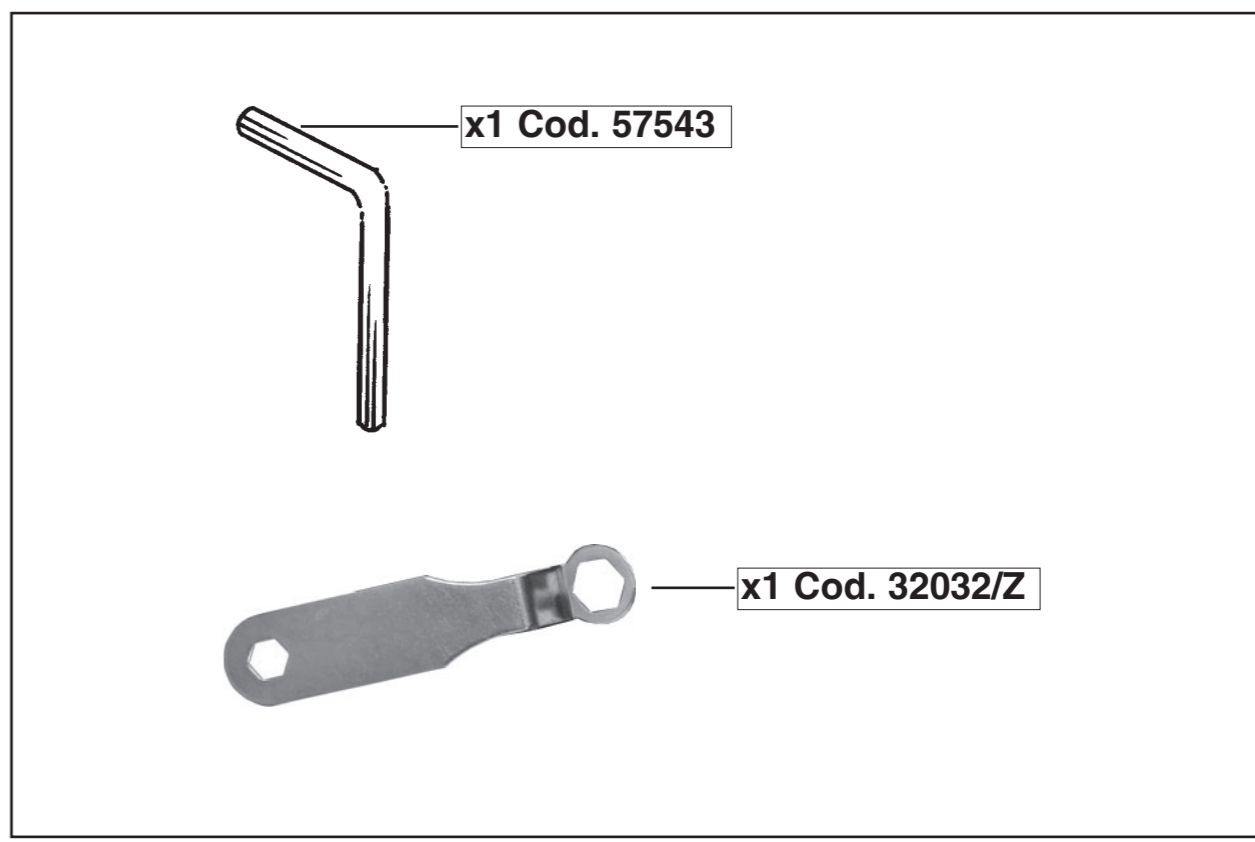
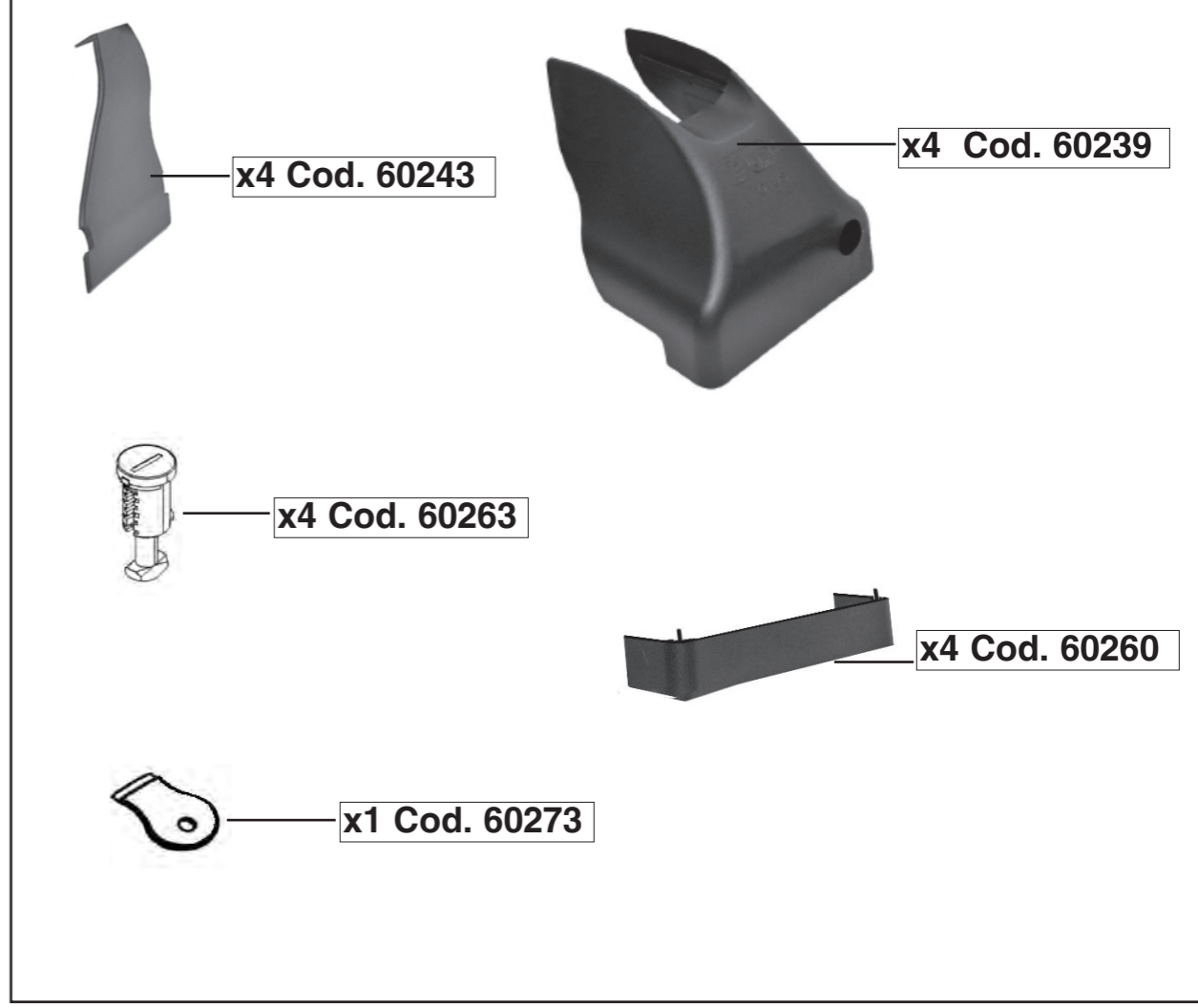
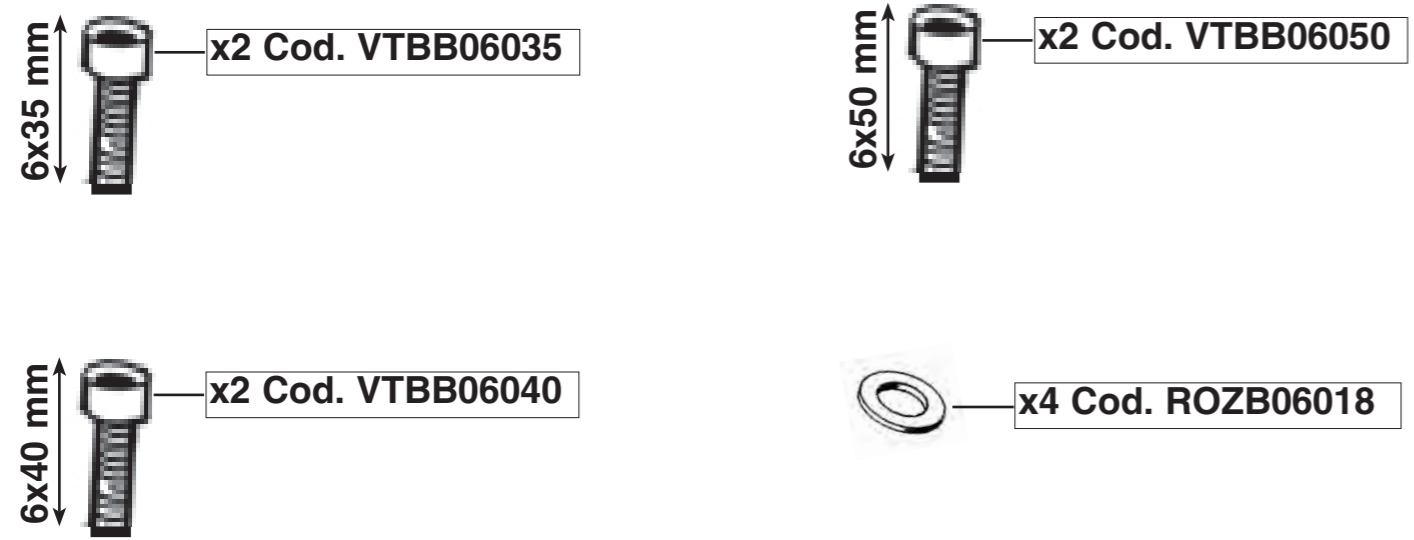
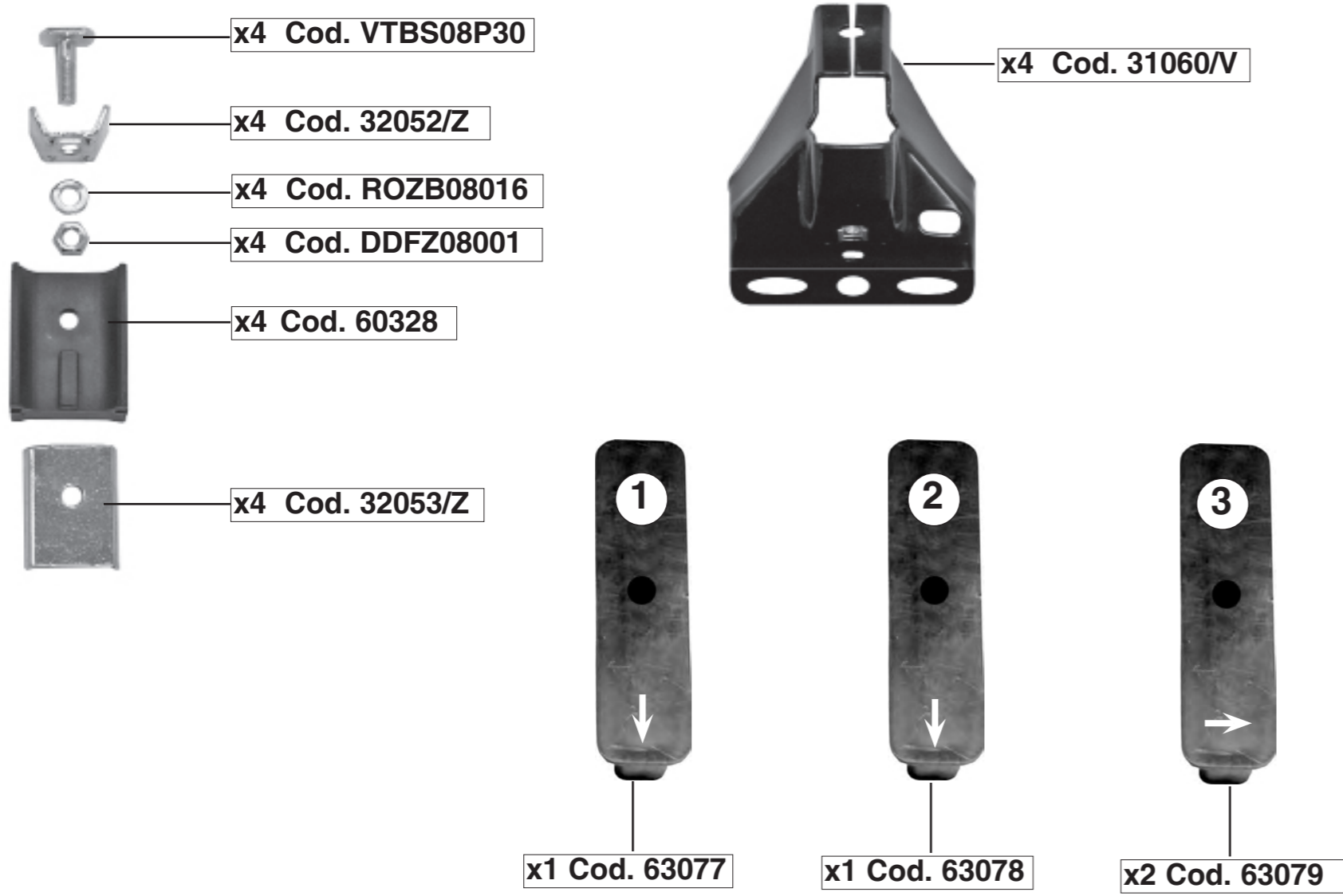

COVER TOTUS

(IT) ISTRUZIONI DI MONTAGGIO (GB) FITTING INSTRUCTIONS (E) INSTRUCCIONES PARA SU MONTAJE
(D) MONTAGEANWEISUNGEN (F) INSTRUCTIONS DE MONTAGE (NL) MONTAGE INSTRUCTIES (P) INSTRUÇÕES DE MONTAGEM
(H) SZERELÉSI UTASÍTÁS (PL) INSTRUKCJA MONTAZU (SLO) NAVODILA O MONTAŽI (HR) UPUTE ZA MONTAŽU.

1



(IT) INSERIRE
(GB) INSERT
(E) CUBRIR
(D) STOPFEN
(F) ENFILER
(P) INSERIR
(NL) BEVESTIG
(H) TOLJA FEL
(PL) NALOZIC
(SLO) VSTAVITI
(HR) PREKRITI



2

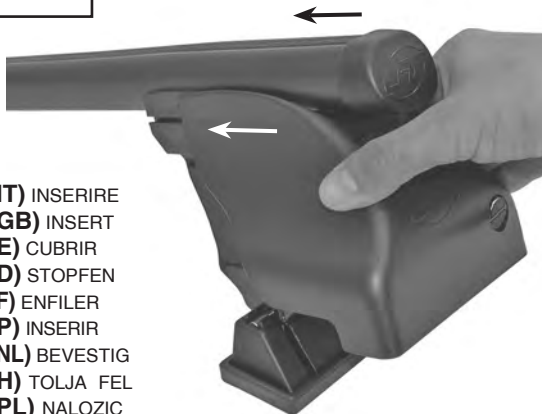

(IT) INSERIRE
(GB) INSERT
(E) CUBRIR
(D) STOPFEN
(F) ENFILER
(P) INSERIR
(NL) BEVESTIG
(H) TOLJA FEL
(PL) NALOZIC
(SLO) VSTAVITI
(HR) PREKRITI

3



4



(IT) INSERIRE
(GB) INSERT
(E) CUBRIR
(D) STOPFEN
(F) ENFILER
(P) INSERIR
(NL) BEVESTIG
(H) TOLJA FEL
(PL) NALOZIC
(SLO) VSTAVITI
(HR) PREKRITI



NO PER ART. 40102 - 40115 - 40119